

PART 3 TRACK RACES

TABLE OF CONTENTS

	Page
Chapter I ORGANISATION	1
Chapter II TRACK RACES	3
§ 1 General observations	3
§ 2 The 200 metres Time Trial	6
§ 3 Sprint	7
§ 4 Individual pursuit	13
§ 5 Team pursuit	17
§ 6 Kilometre and 500 metres Time Trial	21
§ 7 Points race	22
§ 8 Keirin	25
§ 9 Team sprint	30
§ 10 Madison	36
§ 11 Scratch	39
§ 12 Tandem	40
§ 13 Motor-pacing	41
§ 14 Elimination race	44
§ 15 Six-day races	46
§ 16 Omnium	49
§ 17 Flying Lap	50
Chapter III UCI INDIVIDUAL TRACK CLASSIFICATION	51
Chapter IV UCI TRACK CYCLING WORLD CUP	64
Chapter V WORLD RECORDS	70
Chapter VI EQUIPMENT AND INFRASTRUCTURE	76
§ 1 Starting blocks	76
§ 2 Motorbikes for motor-pacing	76
§ 3 Mopeds	79
§ 4 Attire of motor-pacers	81
§ 5 Attire of moped pacers	82
§ 6 Velodromes	83

Chapter VII TRACK TEAMS	91
§ 1 Identity	91
§ 2 Legal and Financial Status	92
§ 3 Registration with UCI	92
§ 4 Teams and Riders	93
§ 5 Contract of Employment	93
§ 6 End of Contract	94
§ 7 Dissolution of a Track Team	94
§ 8 Penalties	94
§ 9 UCI Model Contract Between a Rider and a Track Team	94
Chapter VIII CALENDAR	98
Chapter IX MASTERS	100
Appendix 1 Request for World Record / Best Performance Homologation	102

PART 3 TRACK RACES

Chapter ORGANISATION**Race Programme**

- 3.1.001** (N) An organiser shall establish a programme each time he holds a race.
- 3.1.002** (N) The programme shall include at least the following details of the organisation:
- mention of the fact that the race will be run under UCI Regulations
 - possibly giving the specific regulations of the race
 - the race programme and schedule
 - a description of the track (length, coating, indoor or outdoor.)
 - location of the Race Headquarters, the drug-test room and the Press room
 - the place and time of the enrolment check and the distribution of riders' numbers
 - the place and time of the meeting of Team Managers
 - the programme for the official ceremonies
 - prizes
 - the composition of the Commissaires Panel
 - the name, address and telephone number of the director of the organisation
 - specification that only the UCI Scale of Penalties shall apply
 - the drug-test regulations that are to apply

Secretariat

- 3.1.003** (N) The organiser shall, for the full duration of the race provide a permanent equipped secretariat in the cycling stadium. A representative of the organiser shall be on hand there at all times.
- 3.1.004** (N) The Race Headquarters shall be maintained until the results have been transmitted to the UCI or, if the commissaires have not yet finished their work, until such time as they have finished.
- 3.1.005** (N) The Race Headquarters shall be equipped with a telephone, a fax machine and a photocopier.

Results

- 3.1.006** As soon as results of the competition are known, the organizer shall transmit them electronically or by fax to the UCI and its national federation within one working day, together with the list of riders having taken the start.

(text modified on 13.06.08).

- 3.1.007** (N) The National Federation of the organiser shall without delay communicate to the UCI any changes made to the results communicated by the organiser.

Security

- 3.1.008** Notwithstanding any legal and administrative provisions that may apply and the duty of each individual to take all due care, the organiser shall ensure that the track, the cycling stadium and all installations are in good condition and do not constitute a danger to security. For an international event, the UCI may require additional facilities or measures, without that the absence of such a request would engage its responsibility.

(text modified on 26.08.04).

- 3.1.009** The number of riders on track shall in no case exceed:
- 20 (15 teams for Madison) on a 200 m track
 - 24 (18 teams for Madison) on a 250 m track
 - 36 (20 teams for Madison) on a 333.33 m track

(text modified on 1.01.03).

- 3.1.010** In no case, can the UCI be held responsible for any defects or any mishaps that may occur.

(text modified on 1.01.03).

**Chapter TRACK RACES****General observations****Participation**

3.2.001 Track competition shall be held in the categories as defined in article 1.1.036

Riders of the under 23 category can take part in elite competitions.

Juniors of 18 years old can take part in competition for categories under 23 and elite.

(text modified on 25.09.07).

Conduct of riders

3.2.002 Riders shall refrain from any collusion, manoeuvre or movement likely to hinder the conduct or distort the result of the race.

In addition, while riding on the track, riders shall at all times be in firm control of the bicycle and have at least one hand on the handlebar (or extension).

(text modified on 30.09.10).

3.2.003 If riders wearing the same team clothing ride in the same race, they shall bear some item to distinguish them.

(text modified on 1.01.02).

3.2.004 Other than when prevented by circumstances beyond their control, all riders qualifying for repechages or the following round of the competition must participate or else they will be disqualified.

3.2.005 Riders may carry no object on them or on their bicycles that could drop onto the track. They may not bear or use on the track any music player or radio communication system.

In addition, any electronic device with display (for instance speedometer or powermeter) must be hidden to that it cannot be read by the riders.

(text modified on 25.09.07; 19.06.09).

3.2.006 A rider may not have the race stopped because of some irregularity of which he considers himself the victim.

3.2.007 Unless otherwise provided, any rider having fallen or left the track to dismount from his bicycle, may

accept help in remounting. He shall resume the race at the point where he left the track, and in the position he occupied before falling or leaving the track.

(text modified on 1.10.11).

3.2.008 Riders may not ride on the blue band unless done involuntarily.

(text modified on 1.01.02).

Riders' numbers

3.2.009 (N) riders shall bear two number panels, save in the following specialities where they shall bear just one: the Km Time Trial, the 500 m Time Trial, the Individual Pursuit, the Team Pursuit and the Team Sprint. Riders shall bear two number panels in all events in the Omnium competition.

(text modified on 1.01.02; 1.02.11).

Commissaires Panel

3.2.010 The composition of the Commissaires Panel is indicated in Article 1.2.116.

Judge-Referee

3.2.011 (N) The President of the Commissaires Panel shall appoint one of the panel as judge-referee. He may not carry out the task himself. The presence of a judge-referee shall be compulsory for the sprint, the keirin, the points race and the madison.

The judge-referee shall solely monitor the conduct of riders in the race and their conformity with the racing regulations. On this issue he shall, alone and immediately, impose penalties and take any other decision required under the regulations.

(text modified on 4.07.03).

3.2.012 The judge-referee shall take up a place on the outside of the track in a calm and isolated area with a good general view across the whole track. He must be provided with a means of communicating directly with the president of the commissaires panel. At the world championships, the Olympic Games and world cup events, the judge-referee shall also have access to a video system permitting slow-motion replay in order to review events in the race. This system must be linked to a TV display located near the finish line that will allow the president of the commissaires panel to privately view the same images. A technician shall be specifically appointed to assist him and operate the video system under his instructions.

(text modified on 1.10.11).

Warnings - disqualification

3.2.013 Any offence not specifically penalised and any unsporting behaviour shall be punished by a warning, indicated by a yellow flag, or by disqualification from the race, indicated by a red flag, according to the gravity of the fault, notwithstanding the fine provided for in article 12.1.007.

If a rider is relegated in the competition, that relegation may also carry with it a warning, depending on the gravity, intent and impact of the fault. A rider receiving a second warning, or being relegated for the third time, is disqualified.

On each occasion the commissaires will indicate at the same time the race number of the faulting rider. The warning and disqualification are relative to one specific competition only.

(text modified on 26.08.04; 10.06.05; 1.02.11).

- 3.2.014** In the event that bicycles are checked on conformity with articles 1.3.006 to 1.3.020 with dedicated measuring devices, Commissaires are entitled to double-check positions after the race on a random basis. Should the bicycle or positions have been modified in infringement with this regulation, the rider will be disqualified.

(article introduced on 10.06.05).

Time-keeping

- 3.2.015** (N) Times shall be taken to the thousandth of a second whenever the time determines the result.

Start

- 3.2.016** The starter, located on the track centre, shall give the start by means a pistol shot. In cases where the start is to be taken from a starting block, the following procedure shall apply: the brakes of the machine shall be released by the electronic system that simultaneously triggers the chronometer. Once the bicycle has been fixed, a clock placed before the rider, counts down the last 50 seconds before the start.

- 3.2.017** Any rider holding up the start for reasons not accepted by the starter shall not be permitted to start.

Stoppage

- 3.2.018** The starter alone shall judge whether to stop the race in case of a false start.

- 3.2.019** Stoppage of the race shall be indicated by a double pistol shot, except for the following races: kilometre and 500 metres time trial.

(text modified on 1.01.02).

- 3.2.020** [abrogated on 4.07.03].

Recognised mishap

- 3.2.021** The following shall be considered recognised mishaps:
- a fall
 - a puncture
 - the breakage of an essential part of the bicycle.

All others incidents are considered un-recognised mishaps.

(text modified on 1.01.02).

Seeding

- 3.2.021 bis** For all competitions, other than World Cups, *World Championships* and *Olympic Games*, riders and teams shall be seeded according to their current UCI Individual Track Classification. Riders/teams with no ranking shall be seeded last in random order by the Commissaires Panel.

For World Cups, *World Championships* and *Olympic Games*, riders and teams shall be seeded by the UCI.

(article introduced on 01.02.11; modified on 1.10.12).

§ 2 The 200 metres Time Trial**Definition**

- 3.2.022** A «200 metres Time Trial» shall take a flying start from the 200 metres line and shall be used to select the participants and rankings for the sprint competition.

(text modified on 1.01.02).

Racing procedure

- 3.2.023** Riders shall take the start in the order determined by the commissaires.

- 3.2.024** The rider shall enter the track as soon as he has been passed by the previous rider who has triggered the timing device.

(text modified on 1.01.02).

- 3.2.025** The rider shall build up speed over a distance depending on the length of the track:

- 250 metres track or smaller: 3.5 laps
- 285,714 metre tracks: 3.0 laps
- 333,33 metre track: 2.5 laps
- 400 metres track and longer: 2.0 laps.

- 3.2.026** [abrogated on 1st January 2002].

- 3.2.027** In case of dead heat, the riders concerned will be classified according to the best time in the last 100 metres. In the case that the last 100 metres time cannot be recorded or if the riders are still tied, the riders concerned will be classified by drawing lots.

(text modified on 30.09.10).

- 3.2.028** In the case of a mishap, the rider shall take a new start. Only one new start will be permitted.

(text modified on 1.01.02; 1.01.04).

§ 3 Sprint**Definition**

3.2.029 The sprint is a race between 2 to 4 riders over 2 or 3 laps.

(text modified on 4.07.03).

Organisation of the competition

3.2.030 The competition shall be organised according to the table in article 3.2.050.

3.2.031 The competition shall at least include:

- 8 riders;
- a 200 meters time trial, flying start;
- 1/4 finals, straight;
- a final for place 5th to 8th;
- 1/2 finals, best of three heats;
- finals 3rd-4th and 1st-2nd, best of three heats.

(article introduced on 30.03.09).

3.2.032 During World Cup competitions, 16 riders shall qualify for the sprint tournament.

(text modified on 26.08.04).

3.2.033 *During World Championships, 24 riders shall participate in the sprint tournament. Prior to the first round a qualifying 200 m time trial shall be run to determine the fastest 24 riders taking part to the sprint tournament and the make up of the heats.*

(text modified on 26.08.04; 10.06.05; 1.02.11).

Sprint Race

3.2.034 [abrogated on 1st January 2002].

3.2.035 On tracks of less than 333.33 metres, races shall be ridden over 3 laps. On tracks of 333.33 metres or more, races shall be ridden over 2 laps.

(text modified on 1.01.03).

3.2.036 Should a rider drop out of a two-up heat, his opponent shall go to the starting line to be declared the winner. He need not cover the distance.

3.2.037 The starting position shall be determined by drawing lots. The rider drawing number 1 shall start on the inside of the track.

In two-heat races, the other rider shall take the position on the inside of the track in the second heat.

For the deciding round, a fresh draw shall take place.

(text modified on 1.01.02).

Race procedure

3.2.038 The start shall be given by whistle.

3.2.039 The rider on the inside of the track, unless overtaken, shall lead at least at walking pace and make no manoeuvre to force his opponent through until reaching the pursuit line on the opposite side of the track. A maximum of two standstills shall be permitted for each race. The maximum period for a standstill shall be 30 seconds following which, the leading rider shall be directed by the starter to continue. If he fails to do so, the starter shall stop the race and declare the other rider the winner of the heat. In a three or four-up race, the race shall be immediately rerun as a two or three-up race, without the relegated rider.

(text modified on 1.01.02; 1.01.04; 1.10.11).

3.2.040 [abrogated on 1st January 2002].

3.2.041 Before the last 200 metre line or the start of the final sprint, riders may avail themselves of the full width of the track but must nevertheless leave sufficient space for their opponent to pass and shall refrain from any manoeuvres that could provoke a collision, a fall or cause any rider to ride off the track.

3.2.042 During the final sprint, even if launched before the last 200 metres, each rider shall remain in his lane up to the finish, unless he has at least a clear cycle-length lead and shall not make any manoeuvre to prevent the opponent from passing.

(text modified on 1.01.02).

3.2.043 A rider may not challenge or pass on the left an opponent riding in the sprinters' lane.

If the leading rider leaves the sprinters' lane and his opponent attempts to pass to his left, he may not return to that lane unless he still has a clear cycle-length lead.

3.2.044 A rider passing on the right of his opponent, who is in the sprinters' lane, may not crowd him or cause him suddenly to reduce speed.

3.2.045 A rider starting the sprint outside the sprinters' lane may not drop into that lane if it is already occupied by his opponent unless there is a clear cycle-length lead.

(text modified on 1.01.02).

3.2.046 Should the leading rider drop down below the measuring line he shall be relegated unless he does so involuntarily and unless, at that moment, the result may be considered a foregone conclusion.

3.2.047 If, in a three or four-up race, a rider behaves in an irregular manner to favour another rider, he shall be relegated. The race shall be immediately rerun as a two or three-up race.

(text modified on 1.01.02).

Race stoppages

3.2.048 The race may be stopped only:

1) in the case of fall.

If the fall be intentionally caused by a competitor, that competitor shall be relegated or disqualified from the tournament according to the gravity of the fault committed and the other competitor declared the winner. In three or four-up heats, the race shall be immediately restarted with the remaining two or three riders.

Should the fall have been caused by a competitor riding too slowly in a curve or by any other unintentional fault, the race shall be restarted and the offending rider shall take the inside of the track.

If the fall is not caused by a competitor committing a fault, commissaires shall decide whether the race is to be restarted with the riders in the same order or whether the positions at the time of the fall should be considered final.

2) in the case of a puncture.

3) in the case of the breakage of an essential part of the bicycle.

In all of these three cases, the commissaires shall decide whether the race is to be restarted with the riders in the same order or whether the positions at the time of the incident should be considered final.

4) in the following cases:

4.a) If a rider loses his balance, falls or touches an opponent or the barrier, the race shall be restarted and the rider in question shall take the inside of the track.

4.b) If the starter observes a flagrant infringement and stops the race before the bell rings to indicate the start of the last lap, the commissaires may relegate or disqualify the rider committing the infringement. The other rider shall be declared the winner or in the case of a three or four-up race, it shall be restarted as a two or three-up race.

(text modified on 1.01.02).

3.2.049 If the rider committing the infringement is not relegated or disqualified, the race shall be restarted and that rider shall take the inside of the track.

(text modified on 1.01.02).

3.2.050 Table of sprint competitions:

WORLD CUP

STARTERS	SYSTEM	EVENT	COMPOSITION	1st	Other(s)
16	1/8 Finals 8 X 2 ⇒ 1 = 8	1	N1 - N16	1A1	To "B" tournament
		2	N2 - N15	2A1	
		3	N3 - N14	3A1	
		4	N4 - N13	4A1	
		5	N5 - N12	5A1	
		6	N6 - N11	6A1	
		7	N7 - N10	7A1	
		8	N8 - N9	8A1	
8	1/4 Finals 4 X 2 ⇒ 1 = 4 (in 2 heats, 3 if required)	1	1A1 - 8A1	1B	For places 5 to 8
		2	2A1 - 7A1	2B	
		3	3A1 - 6A1	3B	
		4	4A1 - 5A1	4B	
4	1/2 Finals 2 X 2 ⇒ 1 = 2 (in 2 heats, 3 if required)	1	1B - 4B	1C1	1C2
		2	2B - 3B	2C1	2C2
4	Finals 2 X 2 ⇒ 1 = 2 (in 2 heats, 3 if required)	1	1C1 - 2C1	1st (gold)	2nd (silver)
		2	1C2 - 2C2	3rd (bronze)	4th

"B" TOURNAMENT

STARTERS	SYSTEM	EVENT	COMPOSITION	1st	Other(s)
8	1/4 Finals 4 X 2 ⇒ 1 = 4	1	1A2 - 8A2	1D1	Ranked to places 13 to 16 according to 200 m TT
		2	2A2 - 7A2	2D1	
		3	3A2 - 6A2	3D1	
		4	4A2 - 5A2	4D1	
4	1/2 Finals 2 X 2 ⇒ 1 = 2	1	1D1 - 4D1	1E1	1E2
		2	2D1 - 3D1	2E1	2E2
4	Finals 2 X 2 ⇒ 1 = 2	1	1E1 - 2E1	9th	10th
		2	1E2 - 2E2	11th	12th

WORLD CHAMPIONSHIPS

STARTERS	SYSTEM	EVENT	COMPOSITION	1st	Other(s)
24	1/16 Finals 12 X 2 ⇒ 1 = 12	1	N1 - N24	1A	Ranked according to 200 m TT Qualifying
		2	N2 - N23	2A	
		3	N3 - N22	3A	
		4	N4 - N21	4A	
		5	N5 - N20	5A	
		6	N6 - N19	6A	
		7	N7 - N18	7A	
		8	N8 - N17	8A	
		9	N9 - N16	9A	
		10	N10 - N15	10A	
		11	N11 - N14	11A	
		12	N12 - N13	12A	
12	1/8 Finals 6 X 2 ⇒ 1 = 6	1	1A - 12A	1B1	1B2
		2	2A - 11A	2B1	2B2
		3	3A - 10A	3B1	3B2
		4	4A - 9A	4B1	4B2
		5	5A - 8A	5B1	5B2
		6	6A - 7A	6B1	6B2
6	Repechages 2 X 3 ⇒ 1 = 2	1	1B2 - 4B2 - 6B2	1C	Ranked according to 200 m TT
		2	2B2 - 3B2 - 5B2	2C	
8	1/4 Finals 4 X 2 ⇒ 1 = 4 (in 2 heats, 3 if required)	1	1B1 - 2C	1D	For places 5 to 8
		2	2B1 - 1C	2D	
		3	3B1 - 6B1	3D	
		4	4B1 - 5B1	4D	
4	1/2 Finals 2 X 2 ⇒ 1 = 2 (in 2 heats, 3 if required)	1	1D - 4D	1E1	1E2
		2	2D - 3D	2E1	2E2
4	Finals 2 X 2 ⇒ 1 = 2 (in 2 heats, 3 if required)	1	1E1 - 2E1	1st (gold)	2nd (silver)
		2	1E2 - 2E2	3rd (bronze)	4th

(text modified on 26.08.04; 10.06.05).

OLYMPIC GAMES

STARTERS	SYSTEM	EVENT	COMPOSITION	1st	Other(s)
18	1/16 Final 9 X 2 ⇒ 1 = 9	1	N1 - N18	1A1	1A2
		2	N2 - N17	2A1	2A2
		3	N3 - N16	3A1	3A2
		4	N4 - N15	4A1	4A2
		5	N5 - N14	5A1	5A2
		6	N6 - N13	6A1	6A2
		7	N7 - N12	7A1	7A2
		8	N8 - N11	8A1	8A2
		9	N9 - N10	9A1	9A2
	Repechages 3 X 3 ⇒ 1 = 3	1	1A2 - 6A2 - 9A2	1B	Ranking according to 200 m TT
		2	2A2 - 5A2 - 7A2	2B	
		3	3A2 - 4A2 - 8A2	3B	
12	1/8 Final 6 X 2 ⇒ 1 = 6	1	1A1 - 3B	1C1	1C2
		2	2A1 - 2B	2C1	2C2
		3	3A1 - 1B	3C1	3C2
		4	4A1 - 9A1	4C1	4C2
		5	5A1 - 8A1	5C1	5C2
		6	6A1 - 7A1	6C1	6C2
	Repechages 2 X 3 ⇒ 1 = 2	1	1C2 - 4C2 - 6C2	1D	For places 9 to 12
		2	2C2 - 3C2 - 5C2	2D	
8	1/4 Final 4 X 2 ⇒ 1 = 4 (in 2 heats, 3 of required)	1	1C1 - 2D	1F	For places 5 to 8
		2	2C1 - 1D	2F	
		3	3C1 - 6C1	3F	
		4	4C1 - 5C1	4F	
4	1/2 Final 2 X 2 ⇒ 1 = 2 (in 2 heats, 3 if required)	1	1F - 4F	1G1	1G2
		2	2F - 3F	2G1	2G2
4	Final 2 X 2 ⇒ 1 = 2 (in 2 heats, 3 if required)	1	1G1 - 2G1	1st (gold)	2nd (silver)
		2	1G2 - 2G2	3rd (bronze)	4th

(text modified on 25.09.07).

§ 4 Individual pursuit**Definition**

3.2.051 Two cyclists compete in a fixed distance. The riders start on opposite sides of the track. The winner is determined by either catching the other rider or recording the fastest time.

(text modified on 1.07.02).

Organisation of the competition

3.2.052 Races shall be run over:

- 4 km for Men
- 3 km for Women
- 3 km for Junior Men
- 2 km for Junior Women.

3.2.053 This event shall be organised in two series:

- 1) The qualifying rounds to select the best 4 riders on the basis of their times.
- 2) the finals
The riders with the two best times shall ride off in the final for first and second place while the two others shall ride off in the final for third and fourth places.

(text modified on 26.08.04).

3.2.054 At the Olympic Games, there shall be 3 phases of competition:

- 1) The qualifying rounds to select the best 8 riders on the basis of their times.
- 2) The first competition round. The 8 fastest riders will be matched as follows:
The rider having obtained the 4th fastest time against the one having obtained the 5th fastest time;
The rider having obtained the 3rd fastest time against the one having obtained the 6th fastest time;
The rider having obtained the 2nd fastest time against the one having obtained the 7th fastest time;
The rider having obtained the fastest time against the one having obtained the 8th fastest time.
- 3) The finals:
The four winners of the first competition round shall contest the finals. The riders with the two best times shall ride off in the final for first and second places while the two others shall ride off in the final for third and fourth places.
- 4) The riders beaten in the first competition round shall be classified in 5th to 8th places on the basis of their times in the semi-finals. If a rider is caught, he shall be classified in 8th place; if several riders are caught they shall be classified in the last places on the basis of the distance which they covered before they were caught.

(article introduced on 26.06.07).

3.2.055 For the qualifying rounds the commissaires shall make up each match from riders presumed to be of equal ability, but without matching the two presumed to be the best.

3.2.056 During the qualifying rounds account shall be taken solely of times.

If a rider is caught he must finish the distance to have a time recorded.

A caught rider may not take pace from his opponent, nor pass him, on pain of disqualification.

3.2.057 In a race between two of the four best riders (finals), if one rider catches the other the race is deemed to have finished.

3.2.058 A rider is considered to have been caught at the point that the chainset on his opponent's bicycle draws level with that on his own bicycle.

3.2.059 If a rider fails to take the start in the first competition round, no substitution shall be made. The rider who fails to start will be classified in 8th place.

If several riders fail to start, they shall be classified in 8th place and above in order of their times in the qualifying rounds. The rider who takes the start must ride alone to set a time to determine the composition of the finals.

(text introduced on 26.06.07).

3.2.060 Should a rider fail to take the start of a final, his opponent is declared the winner.

A rider failing to start the final for 1st and 2nd places shall be placed 2nd; a rider failing to start the final for 3rd and 4th places shall be placed 4th. If the reason for failing to ride is not accepted, the absent rider shall be disqualified and his place shall remain vacant.

3.2.061 In the event that riders record the same times, the rider who records the best time for the final lap shall be declared the winner.

(text modified on 13.06.08).

Preparation of the track

3.2.062 The blue bands shall be made impassable round the bankings by the placing every 5 metres of 50 cm long pads of a synthetic material.

3.2.063 At the start the two riders shall be positioned at diametrically opposite points on the track.

3.2.064 The starting point in front of the main stand shall be marked by a red disc. The starting point in the back straight shall be marked by a green disc.

3.2.065 (N) At each finishing point a device shall be set up to record the time of each rider and trigger a green light and a red light to indicate the passing of the respective riders.

3.2.066 A lap counter and a bell shall be set up at each rider's finish line.

3.2.067 (N) The order of passing, the number of laps completed, the time of each rider and the difference in time between the two riders on each half-lap and the final time of each rider will be displayed on the electronic scoreboard.

3.2.068 On tracks whose size is such that the distance to be ridden does not comprise a complete number of laps, the point of the final kilometre shall be marked by a red pennant for the rider who starts from the red disc and a green pennant for the rider starting from the green disc. In competitions for Junior Women the last 500 meters will be marked.

(text modified on 20.09.05).

3.2.069 (N) At the start, each rider shall be held in a starting block.

Race procedure

3.2.070 The start shall be taken on the inside edge of the track.

3.2.071 Riders starting point:

- a) for the qualifying rounds, the commissaires shall determine the starting point for each rider.
- b) in a first competition round, the rider who has recorded the best time in the qualifying rounds will finish in front of the main grandstand.
- c) in the final, the rider who has in the previous round recorded the best time shall finish in front of the main grandstand.

(text modified on 1.01.02; 26.08.04; 26.06.07).

3.2.072 The starter shall stop the race with a double pistol shot in the event of a false start. The course will then be restarted.

A rider who causes two false starts in the qualifying round shall be eliminated.

A rider who causes two false starts during the finals, loses the final.

(text modified on 20.09.05).

3.2.073 During the finals, a pistol shot shall mark the end of the race at the moment on which each rider crosses his finish line at full distance or at the moment that one rider catches the other.

(text modified on 1.10.11).

Mishaps**3.2.074** Qualifying rounds:

In the first half-lap, in the event of a mishap, the race is stopped and restarted immediately.

After the first half-lap the race shall not be stopped. A rider who is the victim of a mishap shall be permitted to ride again at the end of the qualifying rounds (either alone against the watch or matched against another rider in the same situation).

A rider may be only permitted to have 2 starts.

(text modified on 1.01.02; 1.01.04).

3.2.075 First competition round and finals:

In the event of a mishap in the first half-lap, the race shall be stopped. It shall be restarted immediately by both riders.

First competition round:

After the first half-lap the race shall not be stopped. A rider who is the victim of a mishap, recognized or not, shall be permitted to ride again alone against the watch at the end of the first competition round. His opponent shall continue to record a time.

The riders eliminated in the first competition round will be placed in accordance with their times.

Finals:

In the event of a mishap before the final kilometre (half-kilometre for Junior Women) the race is interrupted and the riders shall restart from their positions within a maximum period of 5 minutes:

- the leading rider on the line of the last half-lap which he completed
- the other rider shall start at a distance before the opposite line calculated by the Commissaires Panel on the basis of the time that he was behind at his last completed half-lap
- the riders shall ride the distance remaining as at the last completed half-lap before the mishap.

The final time shall be obtained by adding the partial times.

Inside the final kilometre (half-kilometre for Junior Women):

If the leading rider suffers a mishap, the result shall stand and he shall be declared the winner. The average speed at the last completed half-lap shall be used to calculate the final time to be awarded.

(text modified on 1.01.02; 1.01.04; 26.08.04; 26.06.07).

3.2.076 In each round, including the final, only one new start may be permitted as a result of mishaps.

(text modified on 1.01.02).

**3.2.076
bis**

[abrogated on 1st January 2002]

§ 5 Team pursuit**Definition**

3.2.077 The team pursuit is a race with two opposing teams, starting on each side of the track. The winner is determined by either catching the other team or recording the fastest time.

The men's and women's event are run over four kilometres by teams of four riders.

(text modified on 1.01.02; 26.06.07; 25.02.13).

Organisation of the competition

3.2.078 Except for the specific details (even implicit) in this sub-section, the rules of the individual pursuit shall apply equally to the team pursuit.

3.2.079 Teams shall be made up of riders entered for this event. The composition of the team may vary from one race to another.

The team manager must notify the commissaires of any changes at least one hour before the relevant competition round start.

(text modified on 1.01.02; 30.09.10).

3.2.080 The time and the classification of each team shall be taken on that of the third rider of each team. The time shall be measured on the front wheel of the third rider of each team.

(text modified on 1.01.02; 1.01.03).

3.2.081 A team is caught when the opposing team (at least 3 riders riding together) arrives at or within a distance of one metre of it.

3.2.082 Qualifying rounds shall be organised to find the 4 best teams, 8 for the Olympic Games.

(text modified on 1.01.02; 26.08.04; 26.06.07).

3.2.083 On tracks of less than 400 metres, each team shall ride alone against the clock. On other tracks the commissaires shall make up each match from teams presumed to be of equal ability, but without matching the two presumed to be the best.

3.2.084 [abrogated on 1.01.02].

3.2.085 This event shall be organised in two phases:
1) The qualifying rounds to select the 4 best teams on the basis of their times;

2) The finals.

The teams having made the two best times shall ride off the final for first and second places, the two others shall ride off the final for third and fourth places.

At the Olympic Games, the 8 Teams recording the best times in the qualifying rounds shall be matched in the first competition round as follows:

The team having obtained the 6th fastest time against the one having obtained the 7th fastest time.

The team having obtained the 5th fastest time against the one having obtained the 8th fastest time.

The team having obtained the 2nd fastest time against the one having obtained the 3rd fastest time.

The team having obtained the fastest time against the one having obtained the 4th fastest time.

All the teams from the first competition round shall dispute the finals. The heats shall be ridden in the inverse order to that stated below.

The winners of the last two heats in the first competition round shall ride the final for first and second places.

The remaining 6 teams shall be ranked according to their times from the first competition round and shall dispute the finals as follows:

The two fastest teams shall ride the final for 3rd and 4th places.

The next two fastest teams shall ride the final for 5th and 6th places.

The final two teams shall ride the final for 7th and 8th places.

(text modified on 1.01.02; 26.08.04; 26.06.07; 1.02.11).

3.2.086 If one team is caught by the other during the finals, the race is over and the catching team shall be declared the winner.

3.2.087 Incomplete teams may not take the start. In the qualifying rounds, incomplete teams shall furthermore be disqualified.

If a team fails to take the start in the first competition round, no substitution shall be made. The team failing to start shall be classified in 8th place.

If several teams fail to start, they shall be classified in 8th place and above in order of their times in the qualifying rounds. If the reason for failing to ride is not accepted by the commissaires panel, the absent team shall be disqualified and its place shall remain vacant. The team that takes the start must ride alone to set a time to determine the composition of the finals.

(text modified on 26.06.07; 1.10.11).

3.2.088 Should a team fail to start in the finals, its opponents shall be declared winners and the team not starting shall be placed second in that heat.

If the reason for failing to ride is not accepted by the commissaires panel, the absent team shall be disqualified and its place shall remain vacant.

(text modified on 1.10.11).

3.2.089 Situations of teams not starting and ties on time shall be decided in accordance with the regulations for the individual pursuit.

If it is necessary to place teams who fall into several of the following categories, the classification shall be drawn up as follows, in decreasing order from the 8th place:

- teams who fail to start (article 3.2.087), then
- teams who have caused two false starts (article 3.2.095), then
- teams relegated for pushing (article 3.2.096), then
- teams left incomplete after mishaps (article 3.2.100), then
- teams caught (article 3.2.085).

(text modified on 1.01.02).

Preparation of the track

3.2.090 (N) An electronic timing strip shall be set up on the pursuit lines in order to judge the finish of the front wheel of the third rider of each team.

(text modified on 1.01.02).

3.2.091 The timing and recording of half-laps completed shall be made on the front wheel of the third rider.

(text modified on 1.02.11).

Race procedure

3.2.092 The riders of each team shall start side by side behind the start line.

The lateral distance between riders shall be one metre.

(N) The rider, placed on the inside of the track, shall be held by a starting orange and shall be the leading rider.

(text modified on 3.03.14).

3.2.093 [abrogated on 3.03.14].

3.2.094 The starter shall stop the race for a false start by a double pistol shot, for example, one of the riders anticipates the start or if the rider on the inside of the track fails to take the lead.

(text modified on 1.01.02).

3.2.095 A team which causes two false starts in the qualifying round shall be eliminated.

A team which causes two false starts in the first competition round shall be relegated to the 8th place.

A team which causes two false starts during the finals loses the final.

(text modified on 1.01.02; 26.08.04; 26.06.07).

3.2.096 Pushing between members of the same team is strictly forbidden on pain of disqualification in the qualifying rounds and relegation in the first competition round. During the finals, that team loses its finals.

(text modified on 1.01.02; 26.08.04; 26.06.07).

3.2.097 When the commissaires see that a team is about to be caught, they shall, in order to avoid a collision with the other team or hinder its progress, signal to the former team with a red flag that it may not effect any more relays and remain at the bottom of the track until the opposing team has passed. Any failure to act on this instruction shall result in the immediate disqualification of the team.

(text modified on 1.01.02).

3.2.098 The race shall be over at the moment that the third rider of each team crosses the finishing line for the final time at full distance or, in the finals, at the point that one team (at least 3 riders riding together) catches the other team.

(text modified on 1.01.02).

Mishaps

3.2.099 During the qualifying round:

During the first half-lap, if any team suffers a mishap the race shall be restarted immediately.

If a mishap occurs after the first half-lap and only one rider is involved, the team may either continue with 3 riders, or stop. If the team chooses to stop, it must do so within one lap of the place of the mishap or they face disqualification. Where practicable, the other team shall continue.

The team of a rider which has stopped following a mishap shall restart at the end of the qualifying rounds, where applicable with another team in the same situation.

If a team suffers a mishap during its subsequent ride, it shall continue with three riders or be disqualified.

In each round, including the final, only one new start may be permitted as a result of mishaps.

(text modified on 1.01.02; 1.02.03; 1.01.04; 26.08.04; 26.06.07; 25.02.13).

3.2.100 During the first competition round and finals:

In the event of a mishap in the first half-lap, the race shall be stopped and restarted. If the team suffers a further mishap during its subsequent ride, it shall be eliminated.

After the first half-lap no mishap will be taken into consideration. The team shall continue if they still have three riders on the track.

Otherwise this team must stop and will be:

- placed last in the first competition round;
- considered beaten in finals.

In each round, including the final, only one new start may be permitted as a result of mishaps.

(text modified on 1.01.02; 26.08.04; 26.06.07).

§ 6 Kilometre and 500 metres Time Trial

Definition

3.2.101 The race known as the «kilometre» or «500 metres» race respectively is an individual time trial race with a standing start.

3.2.102 During the World Cup and World Championships, this race is run over a distance of 1000 metres for men and 500 metres for women.

Organisation of the competition

3.2.103 *At the World Championships, each participant shall take the track alone.*

3.2.104 The starting order shall be set by commissaires.

3.2.105 [abrogated on 1.02.11].

3.2.106 The races shall be ridden directly as a final.

3.2.107 In the case of a draw for the three best times, an identical medal shall be awarded to each rider concerned.

3.2.108 All competitors must ride the course at the same meeting. If it is not possible for all the participants to ride this race, for example because of atmospheric conditions, the entire race shall be rerun at the following meeting and no account shall be taken of the times previously made.

Race procedure

3.2.109 The blue band shall be rendered impracticable in the bends by pads of synthetic material 50 cm long, placed at 5 metre intervals.

3.2.110 (N) The rider shall be held at the start by a starting block.

3.2.111 The start shall be taken on the inside edge of the track.

- 3.2.112** In the case of a false start the rider shall restart immediately.
In the case of a mishap, the rider shall take a new start after a rest of approximately 15 minutes.

A rider may be only permitted to have a total of 2 starts.

(text modified on 1.01.02; 1.01.04).

- 3.2.113** [abrogated on 1st January 2002].

§ 7 Points Race

Definition

- 3.2.114** The Points Race is a speciality in which the final placings are determined according to accumulated points won by riders during the sprints and by taking laps.

(text modified on 1.01.02; 1.01.03).

Organisation of the competition

- 3.2.115** According to the number of riders entered for the speciality, the commissaires may possibly compose qualifying heats and shall determine how many of the best placed riders from each heat are to participate in the final.

- 3.2.116** On the 250 metres track or shorter, intermediate sprints shall be run off every 10 laps.

On other tracks, intermediate sprints are run off after each number of laps closest to 2 km, that is to say:

- every 7 laps on 285.714 metres tracks
- every 6 laps on 333.33 metres tracks
- every 5 laps on 400 metres tracks

3.2.117 The competition shall be held over the distances, number of laps and number of sprints as shown in the following table:

TRACK LENGTH	MEN				WOMEN				JUNIOR MEN		JUNIOR WOMEN	
	Qualifying		Final		Qualifying		Final		Final		Final	
	15 km		30 km		10 km		20 km		15 km		10 km	
(in m)	Laps	Sprint	Laps	Sprint	Laps	Sprint	Laps	Sprint	Laps	Sprint	Laps	Sprint
250	60	6	120	12	40	4	80	8	60	6	40	4

TRACK LENGTH	MEN				WOMEN				JUNIOR MEN		JUNIOR WOMEN	
	Qualifying		Final		Qualifying		Final		Final		Final	
	16 km		30 km		10 km		20 km		16 km		10 km	
(in m)	Laps	Sprint	Laps	Sprint	Laps	Sprint	Laps	Sprint	Laps	Sprint	Laps	Sprint
285,714	56	8	105	15	35	5	70	10	56	8	35	5
333,33	48	8	90	15	30	5	60	10	48	8	30	5
400	40	8	75	15	25	5	50	10	40	8	25	5

During World Championships the distances, number of laps and number of sprints shall be as shown in the following table:

TRACK LENGTH	MEN		WOMEN		JUNIOR MEN		JUNIOR WOMEN	
	Final		Final		Qualifying		Final	
	40 km		25 km		15 km		25 km	
(In m)	Laps	Sprint	Laps	Sprint	Laps	Sprint	Laps	Sprint
250	160	16	100	10	60	6	100	10

TRACK LENGTH	MEN		WOMEN		JUNIOR MEN		JUNIOR WOMEN	
	Final		Final		Qualifying		Final	
	40 km		24 km		16 km		24 km	
(In m)	Laps	Sprint	Laps	Sprint	Laps	Sprint	Laps	Sprint
285,714	140	20	84	12	56	8	84	12
333,33	120	20	72	12	48	8	72	12
400	100	20	60	12	40	8	60	12

(text modified on 1.01.02; 1.01.03; 30.03.09).

3.2.118 The first rider in each sprint shall be awarded 5 points, the second 3 points, the third 2 points and the fourth one point.

Any rider that gains a lap on the main field is awarded 20 points.

Any rider that loses a lap on the main field is deducted 20 points.

(text modified on 1.01.02; 1.01.03).

3.2.119 Where two or more riders are equal on points, the places in the final sprint shall declare the winner.

(text modified on 1.01.02; 1.01.04).

Race Procedure

3.2.120 Before the start, half of the riders shall be lined up along the railings, the other half lining up in single file in the sprinter's lane.

3.2.121 A flying start shall be taken after one neutralised lap.

3.2.122 Sprints shall be run according to the rules governing sprint races.

3.2.123 A rider shall be considered to have gained a lap and be awarded 20 points when he has caught up with the rear of the largest bunch.

(text modified on 1.01.02; 1.01.03; 1.02.03).

3.2.124 A rider having dropped behind the bunch and having been caught up may not lead, under penalty of disqualification.

3.2.125 If at the moment of a sprint considered for classification, one or some rider(s) catch up with the main bunch, this (these) rider(s) shall gain a lap and be awarded 20 points. The points awarded for the sprint shall be given immediately to the riders of the break behind or to those ahead of the bunch.

(text modified on 1.01.02; 1.01.03).

3.2.126 Riders having dropped behind the bunch and having been caught up by one or more riders about to gain a lap may not lead these riders, under pain of disqualification.

(text modified on 1.01.02; 1.01.03).

3.2.127 Riders one or several laps down may be withdrawn by the commissaires panel.

(text modified on 1.01.02).

3.2.128 In the event of collusion between riders, the (N) judge-referee may disqualify the riders concerned, possibly after a warning.

3.2.129 In the case of a recognised mishap, the rider shall be entitled to a neutralisation during the number

of laps closest to 1300 metres. On returning to the track, he shall resume the position he occupied before the mishap.

(text modified on 1.01.02; 1.01.04).

3.2.130 Neutralised riders may not return to the track within the last kilometre. Should this last kilometre start within the allowed neutralisation period of a recognised mishap, and the riders not be able to return prior to the start of the last kilometre, these neutralised riders shall appear in the final placings depending on the points accumulated prior to the mishap.

(text modified on 20.09.05; 1.10.11).

3.2.131 Should more than half the riders fall, the race shall be stopped and the commissaires shall determine the duration of the interruption. A new start shall be taken from the positions at the moment of the fall.

3.2.132 A rider suffering a recognised mishap in the last five laps may not return to the track but shall nevertheless appear in the final placings depending on the laps won or lost and the points accumulated prior to the mishap.

Other riders not finishing the race shall be excluded from the final placings.

3.2.133 If the track becomes impracticable to race for any reason, the commissaires shall decide as follows:

DISTANCE	DECISIONS		
	Complete rerun the same day	Resume race with points accumulated	Let results stand
	Stopped before:	Stopped after:	Stopped after:
10 km	8 km	/	8 km
15/16 km	10 km	/	10 km
20 km	10 km	10-15 km	15 km
24/25 km	10 km	10-20 km	20 km
30 km	15 km	15-25 km	25 km
40 km	15 km	15-30 km	30 km

(text modified on 1.01.02; 1.01.03).

§ 8 Keirin

Definition

3.2.134 Riders compete in a sprint after completing a number of laps behind a motorized pacer who leaves the track 600/700 meters before the finish.

(text modified on 1.01.02).

3.2.135 Organisation of the competition

The competition shall at least include:

- 12 riders;
- a qualifying round, 2 heats of 6 riders;
- a final for places 7 to 12;
- a final for places 1 to 6.

The competition shall be organised as shown in the following tables:

1st round	
No. of riders	No. of riders per heat
12 to 14	2 6-7 Top 3 in final 1-6 4th to 6th in final 7-12

No. of riders	1st round		Repechages			1/2 finals	
	No. of heats	No. of riders per heat	No. of heats	No. of riders per heat	Riders qualified per heat for the 1/2 finals	No. of heats	No. of riders per heat
15 to 21	3	5-7	2	2-3	2-3	2	6
22 to 28	4	5-7	2	4	3-5		
29 to 42	6	4-7	1	6	3-6	1	Top 3 in final 1-6 Others in final 7-12

No. of riders	1st round			Repechages			1/4 finals			Repechages			1/2 finals		
	No. of heats	No. of riders per heat	Riders qualified per heat for the 1/4 finals	No. of heats	No. of riders per heat	Riders qualified per heat for the 1/4 finals	No. of heats	No. of riders per heat	Riders qualified per heat for the 1/2 finals	No. of heats	No. of riders per heat	Riders qualified per heat for the 1/2 finals	No. of heats	No. of riders per heat	
43 to 49	7	6-7	1	6	6-7	2	3	6-7	2	2	6-7	3	2		Top 3 in final 1-6 Others in final 7-12
50 to 56	8	6-7	1	7	6-7	2	4	5-6	2	2	7	2	2	6	
57 to 63	9	6-7	1	8	6-7	2	4	6-7	2	4	4-5	1	4		
64 to 70	10	6-7	1	9	6-7	2	4	7	2	4	5	1	4		

TRACK LENGTH	NO. OF LAPS	PACER (No. of laps to the finish)
250	8	2.5
285.714	7	2.5
333.33	6	2
400	5	1.5

**COMPOSITION EXAMPLE OF KEIRIN EVENTS
INVOLVING 28 RIDERS**

1 st ROUND:	Composition:	4 HEATS of 7 riders			
		A	B	C	D
		R1	R2	R3	R4
		R8	R7	R6	R5
		R9	R10	R11	R12
		R16	R15	R14	R13
		R17	R18	R19	R20
		R24	R23	R22	R21
		R25	R26	R27	R28
		Abbreviations: «R» Rank on the last UCI Individual Track Classification. In the absence of rank, drawing lots.			
REPECHAGES:	Results:	*QA1	*QB1	*QC1	*QD1
		*QA2	*QB2	*QC2	*QD2
		QA3	QB3	QC3	QD3
		QA4	QB4	QC4	QD4
		QA5	QB5	QC5	QD5
		QA6	QB6	QC6	QD6
		QA7	QB7	QC7	QD7
		*Riders qualified for 2 nd Round (Semi-finals)			
	Composition:	4 HEATS of 5 riders			
		QA3	QB3	QC3	QD3
	QD4	QC4	QB4	QA4	
	QC5	QB5	QA5	QD5	
	QB6	QA6	QD6	QC6	
	QA7	QD7	QC7	QB7	
	Results:	*RA1	*RB1	*RC1	*RD1
	*Riders qualified for 2 nd Round (Semi-finals)				

COMPOSITION EXAMPLE OF KEIRIN EVENTS INVOLVING 28 RIDERS (CONTINUATION)													
2 nd ROUND: (1/2-finals)	Composition: 2 HEATS of 6 riders												
	FA FB												
	<table border="1" style="margin-left: auto; margin-right: auto;"> <tr><td>QA1</td><td>QB1</td></tr> <tr><td>QD1</td><td>QC1</td></tr> <tr><td>QB2</td><td>QA2</td></tr> <tr><td>QC2</td><td>QD2</td></tr> <tr><td>RA1</td><td>RB1</td></tr> <tr><td>RD1</td><td>RC1</td></tr> </table>	QA1	QB1	QD1	QC1	QB2	QA2	QC2	QD2	RA1	RB1	RD1	RC1
	QA1	QB1											
	QD1	QC1											
	QB2	QA2											
	QC2	QD2											
	RA1	RB1											
	RD1	RC1											
	Results:												
<table border="1" style="margin-left: auto; margin-right: auto;"> <tr><td>*FA1</td><td>*FB1</td></tr> <tr><td>*FA2</td><td>*FB2</td></tr> <tr><td>*FA3</td><td>*FB3</td></tr> <tr><td>**FA4</td><td>**FB4</td></tr> <tr><td>**FA5</td><td>**FB5</td></tr> <tr><td>**FA6</td><td>**FB6</td></tr> </table>	*FA1	*FB1	*FA2	*FB2	*FA3	*FB3	**FA4	**FB4	**FA5	**FB5	**FA6	**FB6	
*FA1	*FB1												
*FA2	*FB2												
*FA3	*FB3												
**FA4	**FB4												
**FA5	**FB5												
**FA6	**FB6												
*Riders qualified for the FINAL 1 - 6													
**Riders qualified for the FINAL 7 - 12													

(text modified on 1.01.02; 30.03.09; 19.06.09).

3.2.136 [abrogated on 1st January 2002].

3.2.137 The pacer shall ride within the sprinter line, starting at 30 kph and shall gradually increase speed to 50 kph which should be achieved at least 4 laps to go (250 m tracks). He shall leave the track as directed by the Commissaires, in principle 600-700 metres before the finish.

For Junior Women and Elite Women the respective speed shall be 25 kph and 45 kph.

(text modified on 1.01.02).

Race procedure

3.2.138 The starting positions of the riders shall be determined by drawing lots. The riders shall be placed side by side in that order on the pursuit line, the sprinters' lane being left free. The riders shall be held, but not pushed, by assistants.

3.2.139 The start shall be given when the pacer approaches the pursuit line in the sprinters' lane. Unless another rider voluntarily takes that position, the rider who drew No.1 shall follow immediately behind the pacer for at least the first lap, failing which the race shall be stopped and that rider disqualified. In the restart, the rider who drew No. 2 shall follow immediately behind the pacer.

(text modified on 1.01.02; 1.02.03; 19.06.09).

3.2.139 bis The riders shall remain immediately behind the pacer until such time as the pacer leaves the track.

(article introduced on 1.10.11).

3.2.140 In the case when one or more riders pass the back wheel of the pacer before he leaves the track, the race will be stopped and rerun without the rider(s) at fault, which will be disqualified.

(text modified on 1.01.02; 19.06.09).

3.2.141 The race shall be run according to the Sprint Regulations.

3.2.142 The race will be stopped if one or more riders are at fault or behave in an unsporting manner while being placed behind the demy. The race will be rerun without the rider(s) at fault, which will be disqualified.

(text modified on 20.09.05; 19.06.09).

3.2.143 A restart will take place immediately if a mishap occurs within the first half-lap.

(text modified on 01.01.02; 20.09.05).

§ 9**Team Sprint**

(text modified on 1.01.02).

Definition

3.2.144 The Team Sprint is a race with two opposing teams, each of whose riders shall lead for one lap.

The men event is run over three laps of a track by teams of three riders.

The women event is run over two laps of a track by teams of two riders.

(text modified on 1.01.02; 19.09.06).

Organisation of the competition

3.2.145 This event shall be organised in two series:

- 1) The qualifying heats to select the 4 best teams on the basis of their times;
- 2) The finals.

The teams having made the two best times shall ride off the final for first and second places, the two others shall ride off the final for third and fourth places.

(text modified on 1.01.02).

3.2.146 At the Olympic Games:

- 1) The qualifying rounds to select the 8 best teams on the basis of their times
- 2) In the first competition round, the 8 best teams shall be matched as follows:
The rider having obtained the 4th fastest time against the one having obtained the 5th fastest time
The rider having obtained the 3rd fastest time against the one having obtained the 6th fastest time
The rider having obtained the 2nd fastest time against the one having obtained the 7th fastest time
The rider having obtained the fastest time against the one having obtained the 8th fastest time.
- 3) The finals
The four winning teams from the first competition round shall dispute the finals. The teams having made the two best times shall ride the final for first and second places and the other two teams shall ride the final for third and fourth places.

Teams beaten during the first competition round shall be placed fifth to eighth according to their times at that stage of the competition.

(text introduced on 26.06.07).

3.2.147 In case of a draw, the best time made during the last lap shall decide.

3.2.148 If a team declares forfeit in a final, it shall not be replaced. The other team shall be declared the winner.

If the reason for which that team did not ride is not accepted, the absent team shall be disqualified.

(text modified on 1.01.02).

3.2.148 bis If a team fails to take the start in the first competition round, no substitution shall be made. The team failing to start shall be classified in 8th place.

If several teams fail to start, they shall be classified in 8th place and above in order of their times in the qualifying rounds. If the reason for failing to ride is not accepted by the commissaires panel, the absent team shall be disqualified and its place shall remain vacant. The team that takes the start must ride alone to set a time to determine the composition of the finals.

(article introduced on 1.10.11).

3.2.149 Teams shall be made up of riders entered for this event. The composition of a team may be modified from one heat to another. An incomplete team may not take the start.

The team manager must notify the commissaires of any changes at least 30 minutes before the relevant competition round start.

(text modified on 1.01.02; 30.09.10).

Race procedure

3.2.150 The start shall be taken in the middle of each straight. During the qualifying races, the place of each team shall be determined by the commissaires. Subsequently, the team having made the best time in the preceding stage of the competition, shall start in front of the main grandstand.

3.2.151 The riders of each team shall start side by side behind the startline.
The lateral distance between riders shall be 1.5 metre.

(N) The rider, placed on the inside of the track, shall be held by a starting block and shall be the leading rider.

(text modified on 01.01.02; 26.08.04; 10.06.05; 3.03.14).

3.2.152 The leading rider shall lead the first lap and move towards the outside of the track and then drop back to leave the track without hindering the other team.

Men:

The rider that was in second position shall lead the following lap and then he shall drop out in the same manner.

The third rider shall end the last lap alone.

Women:

The second rider shall end the last lap alone.

(text modified on 19.09.06).

3.2.153 At the completion of his lap, the rear of the leading rider's back wheel must cross the pursuit line ahead of the leading edge of the front wheel of the following rider. Thereafter, the leading rider must draw aside immediately and ride above the sprinter's line within 15 meters after the pursuit line.

Pushing between members of the same team is strictly forbidden.

If any of the requirements above is not met, the team shall be relegated to the last place in the stage of the competition.

(text modified on 1.01.02; 1.10.12).

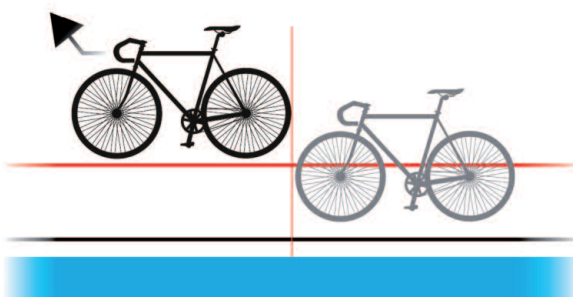
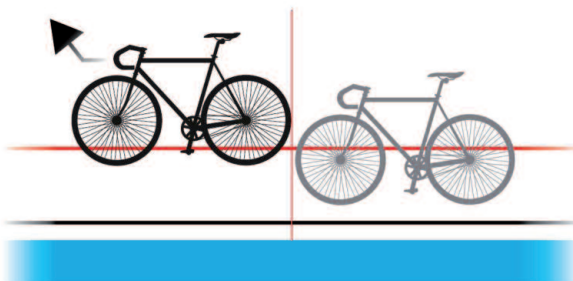
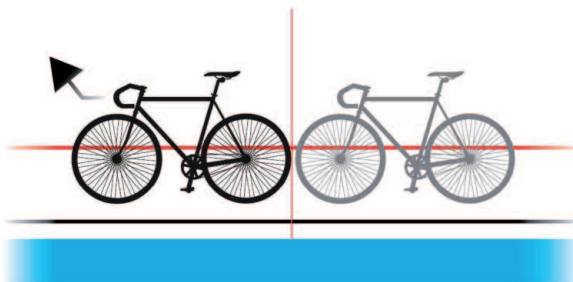

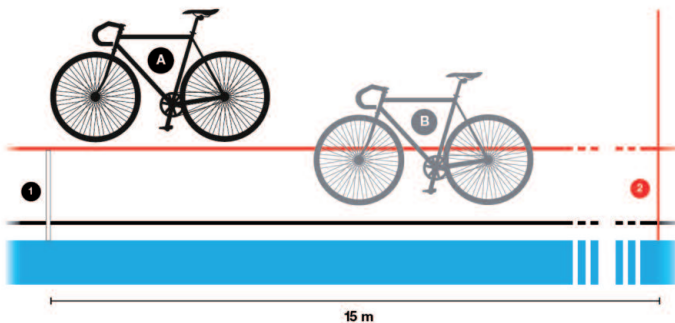
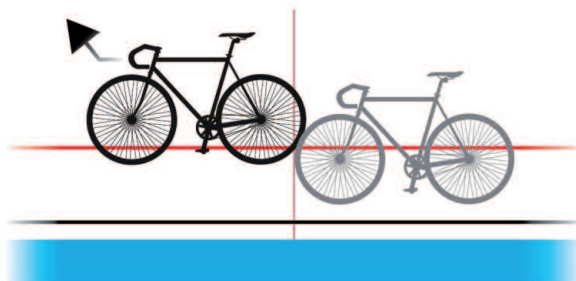
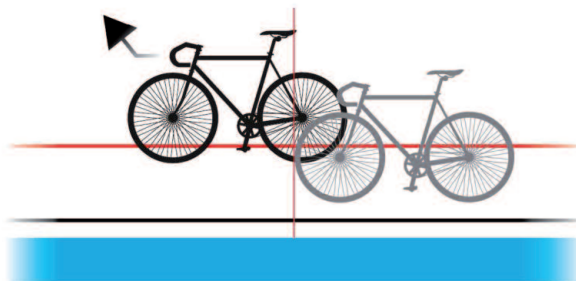

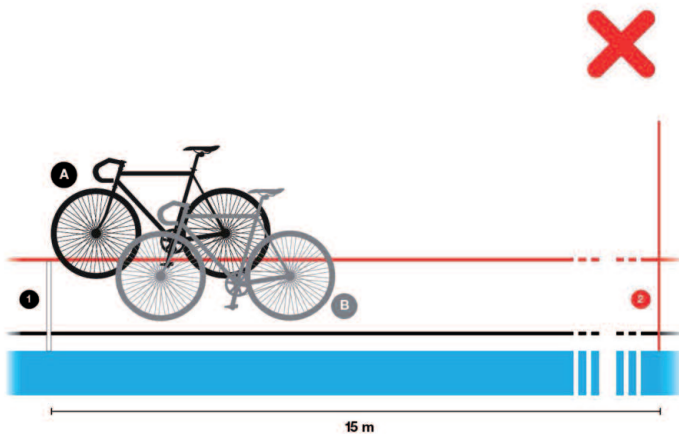
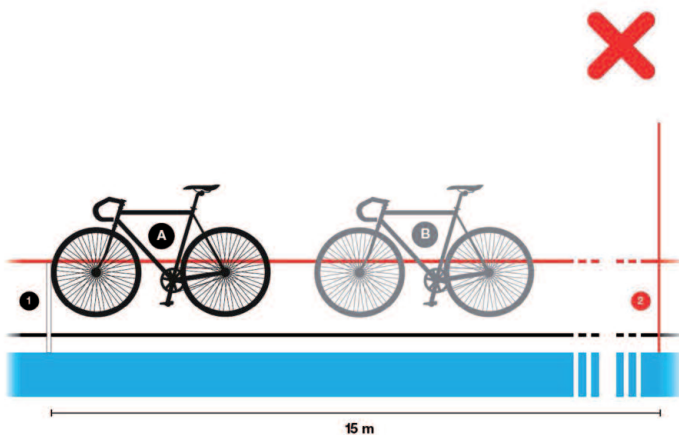
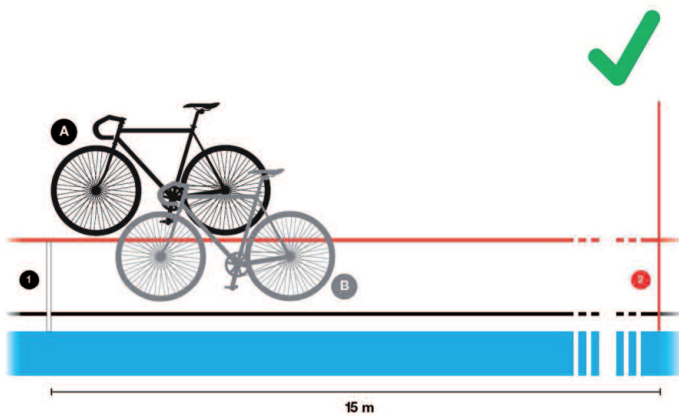

3.2.154 Qualifying rounds:

In the event of a mishap, the team must restart at the end of the qualifying rounds. Any team which may have been hindered by a mishap to its opponents may, by decision of the commissaires' panel, be granted a restart at the end of the qualifying rounds.

In the qualifying rounds a team may only be permitted two starts.

(text modified on 1.01.02).

3.2.155 First competition round and finals:

In the event of a mishap the race shall be stopped and restarted. If the team suffers a further mishap during its subsequent ride, it shall be relegated.

In each round, including the final, only one new start per team shall be permitted as a result of mishaps.

(text modified on 1.01.02; 26.08.04; 26.06.07).

§ 10 Madison

Definition

3.2.156 The Madison Race is a race run over with intermediate sprints involving teams of 2 riders.

The ranking is determined on distance plus accrued points.

(text modified on 1.01.02).

Organisation of the competition

3.2.157 The competition shall at least be held over the distances, number of laps and number of sprints as shown in the following table:

Track length in meters	Number of laps		Number of sprints		Total distance in kilometres	
	Elite Men	Junior Men	Elite Men	Junior Men	Elite Men	Junior Men
200	125	100	5	4	25	20
250	100	80			25	20
285.714	90	72			25.71	20.57
333.33	75	60			25	20
400	65	52			26	20.8

(text modified on 1.01.02; 30.03.09).

3.2.158 The two riders of each team shall carry the same rider number but of different colours.

3.2.159 *At World Championships, each National Federation may enter just one team.*

3.2.160 *At World Championships, intermediate sprints shall be run every 20 laps, whatever the track length can be, for a total distance equal or close to 50 km for Elite Men and 30 km for Junior Men, according to the following table.*

Track length in metres	Number of laps		Number of sprints		Total distance in kilometres	
	Elite Men	Junior Men	Elite Men	Junior Men	Elite Men	Junior Men
250	200	120	10	6	50	30
285,714	180	100	9	5	51.4	28.57
333,33	160	100	8	5	53.3	33.33
400	120	80	6	4	48	32

(text modified on 1.01.02).

3.2.161 The first team in each intermediate sprint shall be awarded 5 points, the second 3 points, the third 2 points and the fourth one point.

(text modified on 1.01.02).

3.2.162 The placing shall be determined by distance according to the number of complete laps covered by each team. Teams having covered the same number of laps are placed according to the number of points scored. Where there is a draw on laps and points, the places in the final sprint shall decide.

(text modified on 1.01.02; 26.08.04).

Race procedure

3.2.163 A first group of riders, formed of one rider of each team, take their places at the start. Half of this group shall be lined up along the outside balustrade and the other half shall be lined up in the sprinters' lane with holders.

A second group of riders, formed of the other riders of each team, shall be lined up along the opposite outside balustrade.

After one neutralised lap, a flying start shall be given to the first group of riders, by means of a pistol shot. During the neutralised lap, the second group of riders must remain motionless.

(text modified on 1.01.02; 19.06.09).

3.2.164 Riders of a same team may relay one another at will by a touch of the hand or the shorts.

3.2.165 Sprints shall be run according to the Regulations governing Sprint.

3.2.166 A team shall be considered to have gained a lap when it catches up with the last rider of the largest bunch. A rider who drops behind the bunch shall not assist chasing rider(s) to gain a lap on the pain of disqualification of his team.

(text modified on 1.01.02).

3.2.167 If at the moment of a sprint considered for classification, one or some rider(s) catch up with the biggest bunch, this (these) rider(s) shall gain a lap. The points shall be given immediately to the riders of the break behind or to those ahead of the bunch.

(text modified on 1.01.02).

3.2.168 Teams lapped three times by the main bunch may be removed by the commissaires.

(text modified on 1.01.02).

3.2.169 Should one of the riders suffer a fall or mechanical incident, his team-mate shall immediately take the team position in the race. There shall be no neutralisation.

3.2.170 Should both team-mates fall simultaneously, the team shall be entitled to a neutralisation equal to the number of laps closest to 1000 m. On returning to the track, one of the two team-mates shall resume the position that the team occupied in the bunch before the mishap.

Neutralised team-mates or teams may not return to the track within the last kilometre. Should both team-mates fall simultaneously in the last kilometre, or should this last kilometre start within the allowed neutralisation period of a recognised mishap for the team and it is not able to return prior to the start of the last kilometre, these neutralised teams shall appear in the final placings depending on the laps won or lost and the points won up to the moment of the mishap.

(text modified on 20.09.05; 1.10.11).

3.2.171 In the case of a fall involving over one-half of the teams (calculated on the basis of one rider per team), the race shall be stopped and the commissaires shall determine the duration of the interruption. A new start shall be taken and each team shall retain the laps won or lost at the moment of the fall.

3.2.172 If the race is called off because of inclement weather, the commissaires shall decide as follows:

	Elite	Junior	
Race stopped before:	20 km	10 km	resume entirely the same day
Race stopped between:	20 and 40 km	10-25 km	resume race with points and laps acquired so far
Race stopped after:	40 km	25 km	let the result stand

(text modified on 1.01.03).

§ 11 Scratch

Definition

3.2.173 The Scratch Race is an individual race over a specified distance.

(text modified on 1.01.02).

Organisation of the competition

3.2.174 The races shall be held over the following distances:

Elite Men	15 km
Elite Women	10 km
Junior Men	10 km
Junior Women	7.5 km

(text modified on 1.01.02).

3.2.175 In order to reach the maximum riders allowed on the track, qualifying heats shall take place to reduce the number of riders entered according to the chart below:

CATEGORY	DISTANCE TO RUN
Men	10 km
Women	7.5 km
Men Junior	7.5 km
Women Junior	5 km

(text modified on 1.01.02; 1.01.03).

Race procedure

3.2.176 Before the start, half of the riders shall be lined up along the railings, the other half lining up in single file in the sprinter's lane.

A flying start shall be taken after one neutralised lap.

(text modified on 1.01.02).

3.2.177 Riders overtaken by the main bunch shall immediately leave the track.

3.2.178 The final placings are determined during the final sprint, taking into account laps gained.

(text modified on 1.01.02; 1.01.03).

3.2.179 [abrogated on 1st January 2002].

3.2.180 In the case of collusion between riders, the commissaires may disqualify the riders concerned.

(text modified on 1.01.02).

3.2.181 The last lap of the race shall be indicated by a bell.

Mishaps

3.2.182 Riders suffering a recognised mishap shall be entitled to a neutralisation during the number of laps closest to 1300 metres.

On returning to the track, he shall resume the position he occupied before the mishap.

Neutralised riders may not return to the track within the last kilometre. Any rider not ending the race will not be placed.

(text modified on 26.08.04; 20.09.05; 30.09.10).

3.2.183 The race may be stopped in the case of a mass fall. The commissaires shall decide whether a fresh start shall be given for the complete distance or for the part of the distance remaining to be ridden from the positions at the moment of the fall.

The same rules shall apply where the race has to be abandoned because of inclement weather.

§ 12 Tandem**Definition**

3.2.184 The «tandem» speciality shall be a «sprint» competition for tandems. It shall be run according to the rules applicable to the «sprint» speciality, except as stipulated below.

Organisation of the competition

- 3.2.185** Each pair of riders shall be considered a single participant.
- 3.2.186** The races shall be run as shown in the table in Article 3.2.050 according to the number of participants and by calculating from the final.
- Nevertheless on tracks of 333.33 metres or less, a heat shall be ridden with a maximum of three tandems.
- 3.2.187** The qualifying heat shall be run over one lap with a flying start.
- 3.2.188** The race shall be run over the following distances:
- on tracks of less of 333.33 metres: 6 laps
 - on tracks of 333.33 metres: 5 laps
 - on tracks of more 333.33 metres: 4 laps
 - on tracks of more of 450 metres: 3 laps

§ 13 Motor-Pacing**Definition**

- 3.2.189** Motor-Pacing is a race in which each rider rides behind a motorcycle-mounted pacer.

Motorcycles and pacers

- 3.2.190** The Federation of the organiser shall provide ten motorbikes (of which two in reserve) complying with the description given in articles 3.6.007 to 3.6.028. The reserve motorcycles shall be used by any pacer or pacers whose motorcycle breaks down.
- 3.2.191** The commissaires shall check the motorcycles, if necessary with the help of a technician experienced in this type of work.
- 3.2.192** The check shall take place at the time indicated by the Commissaires Panel before each race.
- 3.2.193** After having been checked, the motorcycles shall be deposited in a locked enclosure, the keys of which shall be held by one of the commissaires. The motorcycles shall not be entrusted to the pacers until they are about to go on track.
- 3.2.194** Between two such checks, each pacer shall always use the same motorcycle.
- 3.2.195** Pacers shall hold a licence.
- 3.2.196** The Chief Commissaire shall designate two reserve pacers. These pacers, throughout the races, shall stand by ready to start up the reserve motorbikes if one of the machines in the race should break down.

Organisation of the competition

- 3.2.197** Pacing races may be held either over a set time (1 hour) or a set distance.

In the latter case, the distances shall be:

- heats: 25 km
- final: 2 legs of 30 km each

3.2.198 All the heats shall be run the same day.

3.2.199 The commissaires shall make up a number of heats according to the number of riders entered for the speciality.

There shall be at least two heats and each heat shall involve a maximum of 8 riders.

If there are two heats, the first three of each heat plus the fourth of the faster heat shall qualify for the final.

If there are three heats, the first two of each heat plus the third of the fastest heat shall qualify for the final.

If there are four or more heats, the winner of each heat plus the second of the fastest heats shall qualify in such a way that there be seven riders in the final.

3.2.200 The final shall be run in two legs at 30-minute intervals.

3.2.201 The following points scale shall be applied to each leg:

1st	50 points
2nd	35 points
3rd	25 points
4th	17 points
5th	11 points
6th	7 points
7th	4 points.

3.2.202 The final placings are obtained by adding the points won by each rider in the two legs. In the case of a draw, the place in the faster leg shall decide.

Race procedure

3.2.203 A demarcation line, known as the "stayers' line" shall be traced at a one-third of the total width of the track, but at a minimum of 2.50 m from of the outer edge.

The remaining part left free shall be wide enough to allow three riders to ride abreast.

3.2.204 Riding outside the demarcation line shall be forbidden. Should a participant do so, his opponents may not pass him on the inside or they will be disqualified.

3.2.205 A challenging rider may ride beyond the demarcation line only to come up on the right of the rider he is challenging, but at all times leaving a maximum of space to allow other riders to challenge also from the right.

3.2.206 The position of riders at the start of each heat and the allocation of motorcycles shall be determined by the drawing of lots on the track itself.

The starting position for the first heat of the final shall also be determined by drawing lots on the track itself. The position at the start of the second heat shall be the reverse of that in the first heat.

3.2.207 Each rider shall have the same pacer throughout the entire competition.

3.2.208 The pacers shall enter the track without the riders. On a signal from the starter, the pacers, after a few laps to warm up, shall take up their positions at the start.

3.2.209 The riders shall be lined up at the start in a set order.

3.2.210 The start of the race shall be given by a pistol shot. After one lap, the riders shall have fallen in behind their pacers.

3.2.211 A bell shall indicate the last lap of the leading rider. The placing shall be determined by the order in which the riders cross the finishing line and by the number of laps covered, it being understood that, once the winner has crossed the finishing line, the other riders shall cross it once only.

3.2.212 In time races, the bell shall be rung a minute before the hour. At the precise moment when the time expires, the timekeeper shall fire a pistol shot and the finishing judge shall draw up the placings on the first crossing of the line according to the distance covered by each competitor.

3.2.213 Once a rider has dropped a lap of behind the leading rider, he may no longer stop, on pain of being eliminated from the race after a single warning.

3.2.214 Any rider falling more than 5 laps behind the leading rider shall be eliminated.

3.2.215 Pacers committing the following faults shall be punished as follows:

Penalty	Flag	Degree
warning	green	A
fine of CHF 500	green and yellow	B
fine of CHF 750 and 15 days' suspension	yellow	C
fine of CHF 1000 and 1 to 3 months' suspension	red	D

Infringement:	1st	2nd	3rd	4th
1) Riding above the stayers' line with an opponent at less than 10 meters	A	B	C	D
2) Riding above the stayers' line when being challenged	B	C	D	
3) Riding above the stayers' line with an opponent along side	B	C	D	
4) Infringement (1), committed by a rider being overtaken	B	C	D	
5) Infringements (2) or (3), committed by a rider being overtaken	C	D		
6) Crowding to the railing while being challenged by an opponent	B	C	D	

- | | | | | |
|--|---|---|---|---|
| 7) Crowding to the railing while being challenged by two opponents | C | D | | |
| 8) Dropping back down with less than a 5 meter lead (cutting in) | C | D | | |
| 9) Attempt to pass four abreast | | D | | |
| 10) Overtaking on the inside | | D | | |
| 11) Riding with only one hand on the handlebar | A | B | C | D |

3.2.216 In the case of a motorcycle breakdown or recognised mishap before the riders join their pacers, a false start shall be indicated and the race shall be restarted.

Should the same thing happen after the riders have joined their pacers, a neutralisation shall be granted for the number of laps closest to 1500 metres, save during the last 5 laps or the last minutes of time races, in which case the race shall continue. The rider having suffered the mishap shall be placed in the position he held at the time of the mishap, if the commissaires consider that his result was a foregone conclusion. If that is not the case, he shall be placed last.

3.2.217 If the track becomes impracticable, the race shall be entirely restarted except if it is stopped during the last ten laps or, the two last minute in time races. In that case, the riders shall be placed according to their positions when they last crossed the finishing line.

§ 14 Elimination Race

Definition

3.2.218 The Elimination Race is an individual race in which the last rider in each intermediate sprint is eliminated.

Organisation of the competition

3.2.219 The organisation of the competition shall be governed by the specific race regulations.

Race procedure

3.2.220 Before the start, half of the riders shall be lined up along the railings, the other half lining up in single file in the sprinter's lane.

(text modified on 29.01.10).

3.2.221 A flying start shall be taken after a neutralised lap during which the riders shall ride in a compact group at a moderate speed.

3.2.222 A sprint shall be run every second lap on tracks of less than 333.33 metres and every lap on tracks of 333.33 metres or more.
On tracks of less than 333.33 metres, each lap that precedes the sprint shall be indicated by a bell.

3.2.223 After each sprint the last rider, according to the position of his rear wheel on the finishing line, shall be eliminated.

If one or more riders are lapped or abandon the race between sprints, they shall be the riders eliminated in the next sprint.

In certain cases, the commissaires may decide to eliminate a rider other than the last rider in the sprint (for example, if a rider passes on the blue band). The President of the commissaires panel shall be responsible for making the final decision on who will be eliminated based on information from the judge-referee and other commissaires.

In all cases, the decision on which riders shall be eliminated must be made and announced prior to the riders crossing the pursuit line on the back straight after the elimination sprint. If no decision can be made by this time, then no riders shall be eliminated until the next sprint.

An eliminated rider shall leave the track immediately, failing which he shall be disqualified. In the case where the rider does not leave the track immediately, the president of the commissaires panel may decide to neutralise the race in order to remove the rider.

(text modified on 18.06.10; 30.09.10; 1.10.11).

3.2.223 Riders eliminated shall be placed in inverse order according to the time of their elimination **bis** (for example, the first rider eliminated is placed last, the second rider eliminated is placed second last, etc).

(article introduced on 18.06.10).

3.2.224 The last two riders remaining in the race shall ride the final sprint. Their placing shall be based on the position of their front wheels on the finishing line.

3.2.225 The fact that a rider may gain a lap shall not count.

3.2.226 In the case of a recognized mishap by one or more riders, as decided by the President of the Commissaires Panel, the race shall immediately be neutralized for a maximum distance of the number of laps closest to 1300 metres to allow the affected riders to return to the bunch. In the case where all riders on the track suffer a recognized mishap, the race shall be neutralized for a maximum of 3 minutes to allow the affected riders to return to the race.

The neutralization shall be indicated by a yellow flag on the start line and all riders on the track shall ride in a compact group at a moderate speed. No account shall be taken of the position of any riders off the front or back of the bunch at the time of the mishap.

The race shall be restarted by the withdrawal of the yellow flag and the firing of the starter's pistol. Any riders not able to rejoin the race at this point shall be eliminated and their position determined according to the time of their elimination. The bell shall be rung the following lap to indicate the start of a sprint lap.

Except in the case when all riders on the track suffer a recognized mishap, once four or fewer riders remain on the track, no neutralization shall be granted, and any riders not finishing shall be eliminated and their position determined according to the time of their elimination.

(text modified on 18.06.10; 30.09.10).

3.2.226 In the event of collusion between riders, the latter shall be disqualified.
bis

(article introduced on 29.01.10).

§ 15 Six-Day Races

3.2.227 A "Six-Day Race" shall last six consecutive days with at least 24 hours' racing time.

3.2.228 The organiser shall be free to set the duration and the programme of the "Six-Day Race" within the limits set in article 3.2.227.

3.2.229 The "Six-Day Race" is a team race, each team comprising 2 or 3 riders who shall all wear jerseys bearing identical riders' number as indicated in article 1.3.044.

3.2.230 A "Six-Day Race" shall be run on a track of minimum length 140 m.

3.2.231 The organiser shall determine the number of teams according to the track length.

3.2.232 At the start of Madisons/chases (handicap races excepted), the illuminated indicator panel shall be set to zero (0) for all teams.

After the end of the Madisons/chases, the illuminated indicator panel shall again show the actual general placings for the race.

On the last day of race, when the final Madisons/chases is being run, the illuminated indicator panel shall indicate the actual general placings at all times.

(text modified on 1.01.04).

3.2.233 [abrogated on 1st January 2004].

3.2.234 Should a mechanical mishap occur and be recognised as valid by the commissaires, or should a rider fall, the team shall be entitled to a 1.5 km neutralisation (number of laps closest to 1.5 km). In the case of an mishap not recognized by commissaires or on expiry of the neutralisation, one of the team members shall resume the race 100% from the position occupied at the moment of the mishap, failing which the team shall be penalised by the number of laps lost.

(text modified on 1.01.04).

3.2.235 Laps gained by a team, one of whose members has been neutralised, shall be recognised only if the rider who remained in the race covers the full distance, i.e. does not miss a single relay.

3.2.236 During a timed Madison/chase, a team reduced to a single rider shall leave the track 10 laps before the end of the Madison/chase.

(text modified on 1.01.04).

3.2.237 The Track Manager, with the agreement of the Commissaires Panel, shall be entitled to create a temporary team comprising riders whose team-mates have been neutralised. Such riders shall wear identical jerseys and numbers. To determine the provisional position of such a provisional team, the number of laps covered by each of the original teams from which the members of the provisional team were drawn shall be added, rounded down to the nearest even number and divided by two.

When the provisional team is finally disbanded, laps gained or lost and any points won shall be credited towards the general placings of the original teams from which each of the members of the provisional team were drawn.

3.2.238 If a rider is neutralised, his team mate shall continue the ongoing chase according to the articles 3.2.235 and 3.2.236. If the neutralised rider is unable to continue the following chase, all the team shall be neutralised.

After the chase, the neutralised team shall be placed in the same position as the closest team in the general classification at the beginning of the race, including the laps lost by this team during the chase. The gained laps shall not be considered.

Moreover, the neutralised team shall be penalised by one lap.

3.2.239 The race doctor may decide to neutralise a rider for a maximum period lasting until 36 hours, after which the rider shall be eliminated.

(text modified on 1.01.04).

3.2.240 Should a rider abandon the race, the team shall be disbanded. The remaining rider shall participate in all the individual events.

If he has not been included in another team within 48 hours, he shall be eliminated.

3.2.241 Should a new team be created, account shall be taken of the placing of the best team disbanded plus one lap's penalty.

The points won by the two teams will be added and divided by two.

3.2.242 Points shall be awarded as follows:

- Team event; Madison, Madison-Elimination, Team Time Trial (500-1000 m): 20, 12, 10, 8, 6, 4 points
- Individual event; Points race, Elimination, Time Trial (1 lap), Derny, Scratch, Keirin: 10, 6, 5, 4, 3, 2 points
- Sprint: 5, 3, 2, 1 points; points double during the final Madison (maximum 6, every 10 laps).

(text modified on 10.06.05; 25.09.07).

- 3.2.243** As it is impossible to run all teams on track together for the same race, the event has to be run in heats. The following procedure shall then apply:
- A. 1 heat with teams from the 1st half of the general classification: with 1 rider or per team: 10-8-6-4-2 points.
- per team (one relay in mid-race): 10, 8, 6, 4, 2 points
 - Madison: 15, 10, 8, 6, 4, 2 points
- 1 heat with teams from the 2nd half of the general classification: with 1 rider or per team: 10-8-6-4-2 points.
- per team (one relay in mid-race): 10, 8, 6, 4, 2 points
 - Madison: 15, 10, 8, 6, 4, 2 points.
- B. 2 heats with teams from the 1st half of the general classification: with 1 rider: 5-4-3-2-1 points.
2 heats with teams from the 2nd half of the general classification: with 1 rider: 5-4-3-2-1 points.

Laps won in races behind dernys do not count for the overall ranking.

(text modified on 1.01.04).

- 3.2.244** Apart from the final Madison/chase of the «Six-Day Race», teams shall be credited with one bonus lap for every 100 points logged.
Bonus laps can also be given in special events like time-trials, but only if all teams are allowed to participate in the event.

(text modified on 1.01.04).

- 3.2.245** All points won in the individual and team events shall count towards the general placings.

All laps won in races in which there is at least one rider of each team on track shall count towards general classification.

Laps won in Elimination races do not count for the overall ranking.

(text modified on 21.01.06).

- 3.2.246** Each day, in addition to the partial classification of the race or stage, a general classification shall also be prepared on the basis of the number of laps completed and points acquired.

The total distance covered over the six racing days, expressed in complete laps, and the total number of points obtained shall determine the final classification.

The points classification shall be used to classify teams with the same number of laps. The team with the greatest number of laps, regardless of the score obtained, shall be declared the winner.

To distinguish team with equal laps and equal points, account shall be taken of the finishing order of the teams in the final sprint.

§ 16 Omnium

(chapter introduced on 07.07.06).

Definition

3.2.247 The omnium is a single competition consisting of six events run with a maximum number of riders set by the track limit (article 3.1.009) which shall be held over two days in the following order:

- 1) Flying lap (against the clock)
- 2) Points race
 - 30 km for elite men
 - 20 km for elite women
 - 15 km for junior men
 - 10 km for junior women
 - (see chart of article 3.2.117 for number of laps and sprints)
- 3) Elimination
- 4) Individual pursuit
 - 4000 meters for elite men
 - 3000 meters for junior men and elite women
 - 2000 meters for junior women
 - (without finals, opposing each time two riders seeded from the overall ranking after the Elimination)
- 5) Scratch race (according to the chart of article 3.2.174)
- 6) Time trial:
 - Kilometre men
 - 500 metres women
 - (each time with two riders on the track, seeded from the overall ranking after the scratch race).

(text modified on 24.09.09; 29.03.10; 18.06.10; 1.02.11).

3.2.247 bis In competitions for which the number of riders entered exceeds the track limit and there is no existing qualification system to establish the number of participating riders, their selection shall be determined as follows:

All riders entered shall first participate in qualifying Points Race heats run over the distance and with the number of sprints, as per the regulations for Points Race heats. The heats shall be run in such a way so as to qualify up to the track maximum number of riders, without necessarily qualifying the maximum number of riders permitted. An equal number of riders shall qualify from each heat to participate in the Omnium.

All riders not qualifying to participate in the Omnium shall be placed jointly in last position. Any riders not finishing any of the qualifying rounds shall not be placed (DNF).

(article introduced on 18.06.10).

Organisation of the competition

3.2.248 Whenever possible, there shall be an interval of at least 30 minutes between two events.

3.2.249 Any rider failing to attempt to start in one of the events shall not be allowed to take part in the subsequent events but shall be considered to have abandoned the competition. He shall therefore figure last in the final classification with the provision "DNF" (did not finish).

3.2.249 bis For all the Points Race, Elimination and Scratch Race, riders shall be lined up in single file along the railing and in the sprinters lane in the order listed on the start list. This order shall be based on the current Omnium ranking.

(article introduced on 1.02.11).

Ranking

3.2.250 A full result shall be produced for each event.

3.2.251 A cumulative total of ranks obtained in each event shall be updated in increasing order after each event. The winner shall be the rider who has obtained the lowest total of rankings.

3.2.251 bis Any rider abandoning or being withdrawn from the Scratch Race or Points Race shall be awarded the ranking of the last available place at that time plus a penalty ranking equal to the last rank points granted to the Flying Lap.

In the case of the Scratch Race, any rider not finishing due to a fall, or due to the fact that they may not return to the track in the final kilometre, shall be awarded the ranking of the last available place for that event.

(text modified on 18.06.10; 1.02.11).

3.2.252 In the event of a tie, the best rider shall be determined by the lowest cumulated time of the time trial events.

§ 17**Flying Lap**

(chapter introduced on 29.01.10).

Definition

3.2.253 The flying lap is a race against the clock with a flying start from the finish line aimed to rank the participant for the omnium event.

(text modified on 18.06.10; 1.10.12).

Race Procedure

3.2.254 Riders shall take the start in the order determined by the commissaires.

- 3.2.255** The rider shall enter the track as soon as he has been passed by the previous rider who has triggered the timing device.
- 3.2.256** The distance to accomplish including the momentum and the lap of the track is fixed as follows, depending on the length of the track:
- | | |
|---------------------------------|----------|
| track of 250 metres or shorter: | 3 laps ½ |
| track of 285,714 metres: | 3 laps |
| track of 333,33 metres: | 2 laps ½ |
| track of 400 metres or longer: | 2 laps. |
- 3.2.257** In case of tie, riders will be ranked according to the best times in the last 200 metres.
- 3.2.258** In case of a mishap, the rider shall take a new start. Only one new start per rider is permitted.



Chapter UCI INDIVIDUAL TRACK CLASSIFICATION

[chapter introduced on 31.05.04].

- 3.3.001** The UCI has created an individual classification system for riders of elite and juniors categories participating in the races referred to in article 3.3.009. Points won in competitions for the under 23 category will be integrated in the elite classification.

This classification shall be called the “UCI Track Individual Classification” and shall be the exclusive property of the UCI.

(text modified on 25.09.07).

- 3.3.002** A classification by nation for men and women, of elite and juniors categories, is also drawn up for each competitions referred to in article 3.3.009 and shall be the exclusive property of the UCI.

For team events, the classification by nation is calculated by summing the points of the best placed riders from each nation in each competition up to the following maximum quota, equal to the regular number of riders composing the team.

MEN

Team Pursuit: 4

Team Sprint: 3

Madison: 2

WOMEN

Team Pursuit: 4

Team Sprint: 2

Once a nation has reached its maximum quota in an event, points of riders over quota of that nation are directly awarded to the next eligible ranked rider from the following nation.

In the case where the same number of points cannot be allocated to each rider eligible for points in the team, these points shall be equally divided amongst the eligible riders.

For individual events, the classification by nation is calculated by summing the points of the four best placed riders from each nation.

Tied nations shall have their relative positions determined by the place of their best rider on the UCI Individual Track Classification.

(text modified on 30.09.10; 25.02.13).

3.3.003 The classification shall be established according to the points obtained by riders participating in Track races on the International calendar, divided into classes according to article 3.8.003.

Track races on the International calendar having 50% and more of the riders per category, being invited, will not be awarded point.

The classification is drawn up over a period of one year by adding the points won since the preceding ranking was drawn up. At the same time, the remaining points obtained up to the same day of the previous year by each rider in international track cycling races are deducted.

The track commission may grant dispensation in case of unpredictable late change of the Elite World Championships dates.

(text modified on 10.06.05; 25.09.08; 1.10.12).

3.3.004 The number of points to be won in each race is indicated in article 3.3.010.

For the competitions in classes 1 to 3, only events matching the participation criterias will award UCI points.

(text modified on 25.02.13).

3.3.005 For each event UCI points will be awarded once per event in each competition.

For the competitions run as a tournament, UCI points will be awarded according to the overall standings of the speciality. In the absence of overall standings, the event which will award the UCI points

shall be clearly identified on the programme of the competition, failing that, the points will not be awarded.

- 3.3.006** National Federations and organisers shall be required, immediately following the end of the race, to transmit to UCI Headquarters by e-mail or telefax the list of starters and complete results. For races over several days, this information shall be transmitted within 72 hours of the end of the last day race.

All National Federations shall immediately communicate any facts or decisions that could result in an amendment to the points obtained by a rider.

Should such information not be transmitted, the Management Committee may declassify the race in question or exclude it from the Calendar, notwithstanding any other penalties provided for in the Regulations.

- 3.3.007** The Individual Classification and the Classification by Nation shall be drawn up at least twice a month.

If need be, the classification of preceding months will be corrected.

- 3.3.008** The UCI Management Committee may award prizes to riders, in accordance with such criteria as it may establish and with their placing within the system of Classification.

Should the Classification be rectified, prizes already awarded shall be returned and given to the entitled riders according to the revised Classification.

Classification of events

- 3.3.009** Olympic Games
World Championships
World Cup
Continental Championships
Regional Games
International events
Classes 1, 2, 3

(text modified on 25.02.13).

Individual Classification

- 3.3.010** Points are awarded according to the following scale, with only the best results of each rider taken into account as follows:
- the best 5 results of each rider in the Sprint and Keirin;
 - the best 3 results of each rider/team in all other specializations.

UCI CYCLING REGULATIONS

Rank	ELITE / JUNIORS					
	World Championships		World Cups*		Continental Championships	
	Olympic games*					
	Men	Women	Men	Women	Men	Women
1	200	200	150	150	120	120
2	180	180	135	135	105	105
3	160	160	120	120	90	90
4	150	150	113	113	85	85
5	140	140	105	105	80	80
6	130	130	98	98	76	76
7	120	120	90	90	73	73
8	110	110	82	82	66	66
9	100	100	74	74	60	60
10	90	90	66	66	54	54
11	80	80	60	60	49	49
12	72	72	54	54	44	44
13	66	66	49	49	39	39
14	60	60	45	45	34	34
15	56	56	42	42	30	30
16	54	54	39	39	28	28
17	48	48	36	36	26	26
18	44	44	33	33	24	24
19	40	40	30	30	22	22
20	36	36	27	27	20	20
21	32	32	24	24	18	18
22	28	28	21	21	16	16
23	24	24	18	18	14	14
24	20	20	15	15	12	12
25 à X	1	1	1	1	1	1

Individual events

* Elite only

Rank	ELITE / JUNIORS					
	World Championships		World Cups*		Continental Championships	
	Olympic games*					
	Men	Women	Men	Women	Men	Women
1	200 (2 x 100)	-	150 (2 x 75)	-	120 (2 x 60)	-
2	180 (2 x 90)	-	135 (2 x 67,5)	-	105 (2 x 52,5)	-
3	160 (2 x 80)	-	120 (2 x 60)	-	90 (2 x 45)	-
4	150 (2 x 75)	-	113 (2 x 56,5)	-	85 (2 x 42,5))	-
5	140 (2 x 70)	-	105 (2 x 52,5)	-	80 (2 x 40)	-
6	130 (2 x 65)	-	98 (2 x 49)	-	76 (2 x 38)	-
7	120 (2 x 60)	-	90 (2 x 45)	-	73 (2 x 36,5)	-
8	110 (2 x 55)	-	82 (2 x 41)	-	66 (2 x 33)	-
9	100 (2 x 50)	-	74 (2 x 37)	-	60 (2 x 30)	-
10	90 (2 x 45)	-	66 (2 x 33)	-	54 (2x 27)	-
11	80 (2 x 40)	-	60 (2 x 30)	-	49 (2 x 24,5)	-
12	72 (2 x 36)	-	54 (2 x 27)	-	44 (2 x 22)	-
13	66 (2 x 33)	-	49 (2 x 24,5)	-	39 (2 x 19,5)	-
14	60 (2 x 30)	-	45 (2 x 22,5)	-	34 (2 x 17)	-
15	56 (2 x 28)	-	42 (2 x 21)	-	30 (2 x 15)	-
16	54 (2 x 27)	-	39 (2 x 19,5)	-	28 (2 x 14)	-
17	48 (2 x 24)	-	36 (2 x 18)	-	26 (2 x 13)	-
18	44 (2 x 22)	-	33 (2 x 16,5)	-	24 (2 x 12)	-
19	40 (2 x 20)	-	30 (2 x 15)	-	22 (2 x 11)	-
20	36 (2 x 18)	-	27 (2 x 13,5)	-	20 (2 x 10)	-
21	32 (2 x 16)	-	24 (2 x 12)	-	18 (2 x 9)	-
22	28 (2 x 14)	-	21 (2 x 10,5)	-	16 (2 x 8)	-
23	24 (2 x 12)	-	18 (2 x 9)	-	14 (2 x 7)	-
24	20 (2 x 10)	-	15 (2 x 7,5)	-	12 (2 x 6)	-
25 ÷ X	1 (2 x 0,5)	-	1 (2 x 0,5)	-	1 (2 x 0,5)	-

Madison

* Elite only

UCI CYCLING REGULATIONS

Rank	ELITE / JUNIORS					
	World Championships		World Cups*		Continental Championships	
	Olympic games*					
	Men	Women	Men	Women	Men	Women
1	400 (4 x 100)	400 (4 x 100)	300 (4 x 75)	300 (4 x 75)	240 (4 x 60)	240 (4 x 60)
2	360 (4 x 90)	360 (4 x 90)	270 (4 x 67,5)	270 (4 x 67,5)	210 (4 x 52,5)	210 (4 x 52,5)
3	320 (4 x 80)	320 (4 x 80)	240 (4 x 60)	240 (4 x 60)	180 (4 x 45)	180 (4 x 45)
4	300 (4 x 75)	300 (4 x 75)	226 (4 x 56,5)	226 (4 x 56,5)	170 (4 x 42,5)	170 (4 x 42,5)
5	280 (4 x 70)	280 (4 x 70)	210 (4 x 52,5)	210 (4 x 52,5)	160 (4 x 40)	160 (4 x 40)
6	260 (4 x 65)	260 (4 x 65)	196 (4 x 49)	196 (4 x 49)	152 (4 x 38)	152 (4 x 38)
7	240 (4 x 60)	240 (4 x 60)	180 (4 x 45)	180 (4 x 45)	146 (4 x 36,5)	146 (4 x 36,5)
8	220 (4 x 55)	220 (4 x 55)	164 (4 x 41)	164 (4 x 41)	132 (4 x 33)	132 (4 x 33)
9	200 (4 x 50)	200 (4 x 50)	148 (4 x 37)	148 (4 x 37)	120 (4 x 30)	120 (4 x 30)
10	180 (4 x 45)	180 (4 x 45)	132 (4 x 33)	132 (4 x 33)	108 (4 x 27)	108 (4 x 27)
11	160 (4 x 40)	160 (4 x 40)	120 (4 x 30)	120 (4 x 30)	98 (4 x 24,5)	98 (4 x 24,5)
12	144 (4 x 36)	144 (4 x 36)	108 (4 x 27)	108 (4 x 27)	88 (4 x 22)	88 (4 x 22)
13	132 (4 x 33)	132 (4 x 33)	98 (4 x 24,5)	98 (4 x 24,5)	78 (4 x 19,5)	78 (4 x 19,5)
14	120 (4 x 30)	120 (4 x 30)	90 (4 x 22,5)	90 (4 x 22,5)	68 (4 x 17)	68 (4 x 17)
15	112 (4 x 28)	112 (4 x 28)	84 (4 x 21)	84 (4 x 21)	60 (4 x 15)	60 (4 x 15)
16	108 (4 x 27)	108 (4 x 27)	78 (4 x 19,5)	78 (4 x 19,5)	56 (4 x 14)	56 (4 x 14)
17	96 (4 x 24)	96 (4 x 24)	72 (4 x 18)	72 (4 x 18)	52 (4 x 13)	52 (4 x 13)
18	88 (4 x 22)	88 (4 x 22)	66 (4 x 16,5)	66 (4 x 16,5)	48 (4 x 12)	48 (4 x 12)
19	80 (4 x 20)	80 (4 x 20)	60 (4 x 15)	60 (4 x 15)	44 (4 x 11)	44 (4 x 11)
20	72 (4 x 18)	72 (4 x 18)	54 (4 x 13,5)	54 (4 x 13,5)	40 (4 x 10)	40 (4 x 10)
21	64 (4 x 16)	64 (4 x 16)	48 (4 x 12)	48 (4 x 12)	36 (4 x 9)	36 (4 x 9)
22	56 (4 x 14)	56 (4 x 14)	42 (4 x 10,5)	42 (4 x 10,5)	32 (4 x 8)	32 (4 x 8)
23	48 (4 x 12)	48 (4 x 12)	36 (4 x 9)	36 (4 x 9)	28 (4 x 7)	28 (4 x 7)
24	40 (4 x 10)	40 (4 x 10)	30 (4 x 7,5)	30 (4 x 7,5)	24 (4 x 6)	24 (4 x 6)
25 à X	2 (4 x 0,5)	2 (4 x 0,5)	2 (4 x 0,5)	2 (4 x 0,5)	2 (4 x 0,5)	2 (4 x 0,5)

Team Pursuit

* Elite only

UCI CYCLING REGULATIONS

Rank	ELITE / JUNIORS					
	World Championships		World Cups*		Continental Championships	
	Olympic games*					
	Men	Women	Men	Women	Men	Women
1	300 (3 x 100)	200 (2 x 100)	225 (3 x 75)	150 (2 x 75)	180 (3 x 60)	120 (2 x 60)
2	270 (3 x 90)	180 (2 x 90)	202,5 (3 x 67,5)	135 (2 x 67,5)	157,5 (3 x 52,5)	105 (2 x 52,5)
3	240 (3 x 80)	160 (2 x 80)	180 (3x 60)	120 (2 x 60)	135 (3 x 45)	90 (2 x 45)
4	225 (3 x 75)	150 (2 x 75)	169,5 (3 x 56,5)	113 (2 x 56,5)	127,5 (3 x 42,5)	85 (2 x 42,5)
5	210 (3 x 70)	140 (2 x 70)	157,5 (3 x 52,5)	105 (2 x 52,5)	120 (3 x 40)	80 (2 x 40)
6	195 (3 x 65)	130 (2 x 65)	147 (3 x 49)	98 (2 x 49)	114 (3 x 38)	76 (2 x 38)
7	180 (3 x 60)	120 (2 x 60)	135 (3 x 45)	90 (2 x 45)	109,5 (3 x 36,5)	73 (2 x 36,5)
8	165 (3 x 55)	110 (2 x 55)	123 (3 x 41)	82 (2 x 41)	99 (3 x 33)	66 (2 x 33)
9	150 (3 x 50)	100 (2 x 50)	111 (3x 37)	74 (2 x 37)	90 (3 x 30)	60 (2 x 30)
10	135 (3 x 45)	90 (2 x 45)	99 (3 x 33)	66 (2 x 33)	81 (3 x 27)	54 (2x 27)
11	120 (3 x 40)	80 (2 x 40)	90 (3 x 30)	60 (2 x 30)	73,5 (3 x 24,5)	49 (2 x 24,5)
12	108 (3 x 36)	72 (2 x 36)	81 (3 x 27)	54 (2 x 27)	66 (3 x 22)	44 (2 x 22)
13	99 (3 x 33)	66 (2 x 33)	73,5 (3 x 24,5)	49 (2 x 24,5)	58,5 (3 x 19,5)	39 (2 x 19,5)
14	90 (3 x 30)	60 (2 x 30)	67,5 (3 x 22,5)	45 (2 x 22,5)	51 (3 x 17)	34 (2 x 17)
15	84 (3 x 28)	56 (2 x 28)	63 (3 x 21)	42 (2 x 21)	45 (3 x 15)	30 (2 x 15)
16	81 (3 x 27)	54 (2 x 27)	58,5 (3 x 19,5)	39 (2 x 19,5)	42 (3 x 14)	28 (2 x 14)
17	72 (3 x 24)	48 (2 x 24)	54 (3 x 18)	36 (2 x 18)	39 (3 x 13)	26 (2 x 13)
18	66 (3 x 22)	44 (2 x 22)	49,5 (3 x 16,5)	33 (2 x 16,5)	36 (3 x 12)	24 (2 x 12)
19	60 (3 x 20)	40 (2 x 20)	45 (3 x 15)	30 (2 x 15)	33 (3 x 11)	22 (2 x 11)
20	54 (3 x 18)	36 (2 x 18)	40,5 (3 x 13,5)	27 (2 x 13,5)	30 (3 x 10)	20 (2 x 10)
21	48 (3 x 16)	32 (2 x 16)	36 (3 x 12)	24 (2 x 12)	27 (3 x 9)	18 (2 x 9)
22	42 (3 x 14)	28 (2 x 14)	31,5 (3 x 10,5)	21 (2 x 10,5)	24 (3 x 8)	16 (2 x 8)
23	36 (3 x 12)	24 (2 x 12)	27 (3 x 9)	18 (2 x 9)	21 (3 x 7)	14 (2 x 7)
24	30 (3 x 10)	20 (2 x 10)	22,5 (3 x 7,5)	15 (2 x 7,5)	18 (3 x 6)	12 (2 x 6)
25 ÷ X	1,5 (3 x 0,5)	1 (2 x 0,5)	1,5 (3 x 0,5)	1 (2 x 0,5)	1,5 (3 x 0,5)	1 (2 x 0,5)

* Elite only

UCI CYCLING REGULATIONS

Rank	ELITE / JUNIORS					
	Class 1		Class 2		Class 3	
	Men	Women	Men	Women	Men	Women
1	80	80	60	60	30	30
2	72	72	54	54	27	27
3	64	64	48	48	24	24
4	58	58	44	44	22	22
5	52	52	40	40	20	20
6	46	46	36	36	18	18
7	40	40	32	32	3	3
8	38	38	28	28	3	3
9	32	32	24	24	3	3
10	26	26	20	20	3	3
11	22	22	6	6	3	3
12	18	18	6	6	3	3
13	8	8	6	6	3	3
14	8	8	6	6	3	3
15	8	8	6	6	3	3
16	8	8	6	6	3	3
17	8	8	6	6	3	3
18	8	8	6	6	3	3
19	8	8	6	6	3	3
20	8	8	6	6	3	3
21	8	8	6	6	3	3
22	8	8	6	6	3	3
23	8	8	6	6	3	3
24	8	8	6	6	3	3
25 à X	1	1	1	1	1	1

Individual events

Rank	ELITE / JUNIORS					
	Class 1		Class 2		Class 3	
	Men	Women	Men	Women	Men	Women
1	80 (2 x 40)	-	60 (2 x 30)	-	30 (2 x 15)	-
2	72 (2 x 36)	-	54 (2 x 27)	-	27 (2 x 13,5)	-
3	64 (2 x 32)	-	48 (2 x 24)	-	24 (2 x 12)	-
4	58 (2 x 29)	-	44 (2 x 22)	-	22 (2 x 11)	-
5	52 (2 x 26)	-	40 (2 x 20)	-	20 (2 x 10)	-
6	46 (2 x 23)	-	36 (2 x 18)	-	18 (2 x 9)	-
7	40 (2 x 20)	-	32 (2 x 16)	-	3 (2 x 1,5)	-
8	38 (2 x 19)	-	28 (2 x 14)	-	3 (2 x 1,5)	-
9	32 (2 x 16)	-	24 (2 x 12)	-	3 (2 x 1,5)	-
10	26 (2 x 13)	-	20 (2 x 10)	-	3 (2 x 1,5)	-
11	22 (2 x 11)	-	6 (2 x 3)	-	3 (2 x 1,5)	-
12	18 (2 x 9)	-	6 (2 x 3)	-	3 (2 x 1,5)	-
13	8 (2 x 4)	-	6 (2 x 3)	-	3 (2 x 1,5)	-
14	8 (2 x 4)	-	6 (2 x 3)	-	3 (2 x 1,5)	-
15	8 (2 x 4)	-	6 (2 x 3)	-	3 (2 x 1,5)	-
16	8 (2 x 4)	-	6 (2 x 3)	-	3 (2 x 1,5)	-
17	8 (2 x 4)	-	6 (2 x 3)	-	3 (2 x 1,5)	-
18	8 (2 x 4)	-	6 (2 x 3)	-	3 (2 x 1,5)	-
19	8 (2 x 4)	-	6 (2 x 3)	-	3 (2 x 1,5)	-
20	8 (2 x 4)	-	6 (2 x 3)	-	3 (2 x 1,5)	-
21	8 (2 x 4)	-	6 (2 x 3)	-	3 (2 x 1,5)	-
22	8 (2 x 4)	-	6 (2 x 3)	-	3 (2 x 1,5)	-
23	8 (2 x 4)	-	6 (2 x 3)	-	3 (2 x 1,5)	-
24	8 (2 x 4)	-	6 (2 x 3)	-	3 (2 x 1,5)	-
25 à X	1 (2 x 0,5)	-	1 (2 x 0,5)	-	1 (2 x 0,5)	-

Madison

UCI CYCLING REGULATIONS

Rank	ELITE / JUNIORS					
	Class 1		Class 2		Class 3	
	Men	Women	Men	Women	Men	Women
1	160 (4 x 40)	160 (4 x 40)	120 (4 x 30)	120 (4 x 30)	60 (4 x 15)	60 (4 x 15)
2	144 (4 x 36)	144 (4 x 36)	108 (4 x 27)	108 (4 x 27)	54 (4 x 13,5)	54 (4 x 13,5)
3	128 (4 x 32)	128 (4 x 32)	96 (4 x 24)	96 (4 x 24)	48 (4 x 12)	48 (4 x 12)
4	116 (4 x 29)	116 (4 x 29)	88 (4 x 22)	88 (4 x 22)	44 (4 x 11)	44 (4 x 11)
5	104 (4 x 26)	104 (4 x 26)	80 (4 x 20)	80 (4 x 20)	40 (4 x 10)	40 (4 x 10)
6	92 (4 x 23)	92 (4 x 23)	72 (4 x 18)	72 (4 x 18)	36 (4 x 9)	36 (4 x 9)
7	80 (4 x 20)	80 (4 x 20)	64 (4 x 16)	64 (4 x 16)	6 (4 x 1,5)	6 (4 x 1,5)
8	76 (4 x 19)	76 (4 x 19)	56 (4 x 14)	56 (4 x 14)	6 (4 x 1,5)	6 (4 x 1,5)
9	64 (4 x 16)	64 (4 x 16)	48 (4 x 12)	48 (4 x 12)	6 (4 x 1,5)	6 (4 x 1,5)
10	52 (4 x 13)	52 (4 x 13)	40 (4 x 10)	40 (4 x 10)	6 (4 x 1,5)	6 (4 x 1,5)
11	44 (2 x 11)	44 (2 x 11)	12 (4 x 3)	12 (4 x 3)	6 (4 x 1,5)	6 (4 x 1,5)
12	36 (4 x 9)	36 (4 x 9)	12 (4 x 3)	12 (4 x 3)	6 (4 x 1,5)	6 (4 x 1,5)
13	16 (4 x 4)	16 (4 x 4)	12 (4 x 3)	12 (4 x 3)	6 (4 x 1,5)	6 (4 x 1,5)
14	16 (4 x 4)	16 (4 x 4)	12 (4 x 3)	12 (4 x 3)	6 (4 x 1,5)	6 (4 x 1,5)
15	16 (4 x 4)	16 (4 x 4)	12 (4 x 3)	12 (4 x 3)	6 (4 x 1,5)	6 (4 x 1,5)
16	16 (4 x 4)	16 (4 x 4)	12 (4 x 3)	12 (4 x 3)	6 (4 x 1,5)	6 (4 x 1,5)
17	16 (4 x 4)	16 (4 x 4)	12 (4 x 3)	12 (4 x 3)	6 (4 x 1,5)	6 (4 x 1,5)
18	16 (4 x 4)	16 (4 x 4)	12 (4 x 3)	12 (4 x 3)	6 (4 x 1,5)	6 (4 x 1,5)
19	16 (4 x 4)	16 (4 x 4)	12 (4 x 3)	12 (4 x 3)	6 (4 x 1,5)	6 (4 x 1,5)
20	16 (4 x 4)	16 (4 x 4)	12 (4 x 3)	12 (4 x 3)	6 (4 x 1,5)	6 (4 x 1,5)
21	16 (4 x 4)	16 (4 x 4)	12 (4 x 3)	12 (4 x 3)	6 (4 x 1,5)	6 (4 x 1,5)
22	16 (4 x 4)	16 (4 x 4)	12 (4 x 3)	12 (4 x 3)	6 (4 x 1,5)	6 (4 x 1,5)
23	16 (4 x 4)	16 (4 x 4)	12 (4 x 3)	12 (4 x 3)	6 (4 x 1,5)	6 (4 x 1,5)
24	16 (4 x 4)	16 (4 x 4)	12 (4 x 3)	12 (4 x 3)	6 (4 x 1,5)	6 (4 x 1,5)
25 à X	2 (4 x 0,5)	2 (4 x 0,5)	2 (4 x 0,5)	2 (4 x 0,5)	2 (4 x 0,5)	2 (4 x 0,5)

Team Pursuit

Rank	ELITE / JUNIORS					
	Class 1		Class 2		Class 3	
	Men	Women	Men	Women	Men	Women
1	120 (3 x 40)	80 (2 x 40)	90 (3 x 30)	60 (2 x 30)	45 (3 x 15)	30 (2 x 15)
2	108 (3 x 36)	72 (2 x 36)	81 (3 x 27)	54 (2 x 27)	40,5 (3 x 13,5)	27 (2 x 13,5)
3	96 (3 x 32)	64 (2 x 32)	72 (3 x 24)	48 (2 x 24)	36 (3 x 12)	24 (2 x 12)
4	87 (3 x 29)	58 (2 x 29)	66 (3 x 22)	44 (2 x 22)	33 (3 x 11)	22 (2 x 11)
5	78 (3 x 26)	52 (2 x 26)	60 (3 x 20)	40 (2 x 20)	30 (3 x 10)	20 (2 x 10)
6	69 (3 x 23)	46 (2 x 23)	54 (3 x 18)	36 (2 x 18)	27 (3 x 9)	18 (2 x 9)
7	60 (3 x 20)	40 (2 x 20)	48 (3 x 16)	32 (2 x 16)	4,5 (3 x 1,5)	3 (2 x 1,5)
8	57 (3 x 19)	38 (2 x 19)	42 (3 x 14)	28 (2 x 14)	4,5 (3 x 1,5)	3 (2 x 1,5)
9	48 (3 x 16)	32 (2 x 16)	36 (3 x 12)	24 (2 x 12)	4,5 (3 x 1,5)	3 (2 x 1,5)
10	39 (3 x 13)	26 (2 x 13)	30 (3 x 10)	20 (2 x 10)	4,5 (3 x 1,5)	3 (2 x 1,5)
11	33 (3 x 11)	22 (2 x 11)	9 (3 x 3)	6 (2 x 3)	4,5 (3 x 1,5)	3 (2 x 1,5)
12	27 (3 x 9)	18 (2 x 9)	9 (3 x 3)	6 (2 x 3)	4,5 (3 x 1,5)	3 (2 x 1,5)
13	12 (3 x 4)	8 (2 x 4)	9 (3 x 3)	6 (2 x 3)	4,5 (3 x 1,5)	3 (2 x 1,5)
14	12 (3 x 4)	8 (2 x 4)	9 (3 x 3)	6 (2 x 3)	4,5 (3 x 1,5)	3 (2 x 1,5)
15	12 (3 x 4)	8 (2 x 4)	9 (3 x 3)	6 (2 x 3)	4,5 (3 x 1,5)	3 (2 x 1,5)
16	12 (3 x 4)	8 (2 x 4)	9 (3 x 3)	6 (2 x 3)	4,5 (3 x 1,5)	3 (2 x 1,5)
17	12 (3 x 4)	8 (2 x 4)	9 (3 x 3)	6 (2 x 3)	4,5 (3 x 1,5)	3 (2 x 1,5)
18	12 (3 x 4)	8 (2 x 4)	9 (3 x 3)	6 (2 x 3)	4,5 (3 x 1,5)	3 (2 x 1,5)
19	12 (3 x 4)	8 (2 x 4)	9 (3 x 3)	6 (2 x 3)	4,5 (3 x 1,5)	3 (2 x 1,5)
20	12 (3 x 4)	8 (2 x 4)	9 (3 x 3)	6 (2 x 3)	4,5 (3 x 1,5)	3 (2 x 1,5)
21	12 (3 x 4)	8 (2 x 4)	9 (3 x 3)	6 (2 x 3)	4,5 (3 x 1,5)	3 (2 x 1,5)
22	12 (3 x 4)	8 (2 x 4)	9 (3 x 3)	6 (2 x 3)	4,5 (3 x 1,5)	3 (2 x 1,5)
23	12 (3 x 4)	8 (2 x 4)	9 (3 x 3)	6 (2 x 3)	4,5 (3 x 1,5)	3 (2 x 1,5)
24	12 (3 x 4)	8 (2 x 4)	9 (3 x 3)	6 (2 x 3)	4,5 (3 x 1,5)	3 (2 x 1,5)
25 à X	1,5 (3 x 0,5)	1 (2 x 0,5)	1,5 (3 x 0,5)	1 (2 x 0,5)	1,5 (3 x 0,5)	1 (2 x 0,5)

Team Sprint

Regional games

The points awarded for the regional games will be in accord with the number of national federations participating, that is to say:

- 5 nations and more: the points are those awarded to an international event of class 1;
- 4 nations: the points are those awarded to an international event of class 2;
- 3 nations: the points are those awarded to an international event of class 3;
- 1 to 2 nations: no point.

Points will only be awarded to the regional championships registered on the UCI International Track Calendar.

When a nation is represented by several regional teams, the points will be awarded to the best rider(s) of this nation up to the maximum number of participants permitted for teams by the specific regulation of each event.

National Championships

The points for the national championships are those awarded to an international event of class 3.

Points will only be awarded to the national championships registered beforehand and appearing on the UCI Track Calendar. The results must reach the UCI electronically or by fax within one working day after the competition is finished.

Where elite and under 23 men compete in the national championships at the same event, points are awarded according to their position in the classification of the event.

For national federations organizing a separate event for the under 23 category, the points are awarded in accordance with the same scale as for the corresponding elite event.

Any rider can claim the award of points in only one category by specialization, where applicable, his own.

Where the title of national champion is awarded at an international event, the riders, regardless of their nationality, shall be awarded the points relative to their position in the classification of that event.

(text modified on 10.06.05; 19.09.06; 25.09.07; 13.06.08; 29.03.10; 1.07.12; 1.02.13; 10.04.13).

3.3.011 The order of precedence between riders on equal points shall be determined according to their classification of events in the following order:

- 1) World Championships;
- 2) World Cups;
- 3) Continental Championships;
- 4) International event of class 1;

- 5) International event of class 2;
- 6) International event of class 3.

If they still stand equal, precedence shall be awarded to the rider with the best classification in the most recent event of the same class.

(article introduced on 13.06.08; 25.02.13).

IV

Chapter UCI TRACK CYCLING WORLD CUP

- 3.4.001** The International Cycling Union has created a «Track Cycling World Cup», comprising a general classification by nation based on a number of competitions designated each year by the UCI Management Committee.
- 3.4.002** The Track Cycling World Cup shall be the exclusive property of the UCI.
- 3.4.003** World Cup events shall be selected from those of the World Championships hereunder:

MEN

- 1) 1 km TT, standing start
- 2) Sprint
- 3) Individual pursuit, 4 km
- 4) Team pursuit, 4 km
- 5) Keirin
- 6) Team sprint
- 7) Points race, 30 km
- 8) Madison, 40 km
- 9) Scratch race, 15 km
- 10) Omnium

WOMEN

- 1) 500m TT, standing start
- 2) Sprint
- 3) Individual pursuit, 3 km
- 4) Team Pursuit, 4 km
- 5) Keirin
- 6) Team sprint
- 7) Points race, 20 km
- 8) Scratch race, 10 km
- 9) Omnium

(text modified on 1.01.02; 1.01.03; 19.09.06; 25.09.07; 29.03.10; 18.06.10; 25.02.13).

Participation

- 3.4.004** The competitions shall be for national selections and registered track teams comprising riders aged 18 and over. The age of a rider shall be determined by the difference between the year of the last leg of the applicable world cup and the year of his birth.

The participation in the individual events shall be restricted to riders with at least 30 points in the respective UCI eligibility ranking **other than for the individual events on the programme of the Olympic Games, where the minimum points required shall be 90 points**. For the development of track cycling, the track commission may grant dispensation of this requirement.

The participation in each competition of the world cup determines the **eligibility** of the national federations to **the corresponding event** of the world championships according to article 9.2.027bis.

(text modified on 1.01.03; 21.01.06; 25.02.13; 10.04.13).

- 3.4.005** Enrolment shall be open to UCI-affiliated National Federations and UCI Track Teams.

The maximum number of riders qualified through the individual classification is determined by the UCI Eligibility Ranking **two months** prior to **the first** leg of the world cup in accordance with the following table:

Speciality	Men	Women
Sprint	45	45
Keirin	36	36
Omnium	24 ²⁾	24 ²⁾
Madison	18 ^{1) 2)}	

¹⁾ Teams.

²⁾ In the presence of the World Champion, the number of teams/riders qualified through the UCI Eligibility Ranking shall be reduced in order not to exceed the applicable maximum number.

There is no maximum number for the other specializations.

The eligibility ranking is established on the basis of the results of class 1, 2, 3 events, national and continental championships.

(text modified on 25.09.07; 1.10.12; 1.02.13; 10.04.13).

3.4.006 Each national team shall comprise a maximum of 17 riders with a maximum of 10 men and 7 women.

(text modified on 25.09.07; 25.02.13).

3.4.007 The maximum number of participants by team (track team or national team) for each race shall be the following:

MEN		WOMEN	
1 km Time Trial	1	500 m Time Trial	1
Sprint	2	Sprint	2
Keirin	1	Keirin	1
Team Sprint	3	Team Sprint	2
Individual pursuit	1	Individual Pursuit	1
Team pursuit	4	Team pursuit	4
Points race	1	Points race	1
Scratch race	1	Scratch race	1
Omnium	1	Omnium	1
Madison	2		

(text modified on 1.01.02; 1.01.03; 26.08.04; 19.09.06; 25.09.07; 29.03.10; 18.06.10; 25.02.13; 10.04.13).

3.4.007 bis The maximum number of riders of the same nationality, irrespective of their team, qualified through the UCI Eligibility Ranking shall be restricted for some specializations as follow:

Sprint	4
Keirin	3

Omnium	1
Madison	1 (team)

In the event where there are more riders/teams of the same nationality entered for the specializations listed above, the selection of the eligible rider/team shall be made by the respective national federation, even if the rider/team is competing with a UCI track team.

(article introduced on 10.04.13).

- 3.4.008** National Federations shall confirm their participation by means of an enrolment form within 6 weeks before the date of the race.

That confirmation shall mention the number of persons making up each delegation.

(text modified on 26.08.04).

- 3.4.009** The names of riders, substitutes and attendants shall reach the organiser by 3 weeks before the date of the race at the latest.

In case of the non-attendance of nominated athletes after confirmation, the following penalties may be imposed:

- A financial penalty equal to the travel costs of the athletes or minimum CHF 2'000.- per athlete. This penalty shall be paid to the organization. The rider's National Federation shall be held jointly liable for paying the penalty.
- The names of the riders taking part must be announced to the Commissaires Panel by noon at the latest on the eve of the first race of the competition as per the published times and instructions. Any announcement made out of the time limit shall be liable to a fine of CHF 2'500.-.

(text modified on 26.08.04; 30.09.10).

- 3.4.009 bis** A rider once registered for a world cup leg must not take part in any other event in any discipline in the week before or after the mentioned leg, under penalty of exclusion from the classification and a fine of CHF 500.- to CHF 3000.-.

The track commission may grant an exemption in case of exceptional circumstances preventing in an unpredictable manner one or more riders from taking part in a competition of the world cup as well as their replacement. The exemption must be requested within the 3 days following the end of the competition.

(article introduced on 10.06.05).

Organisation

- 3.4.010** Organisers of World Cup races shall sign a contract with the UCI governing, notably, the radio and TV broadcasting rights, marketing rights and the material organisation of the races.

3.4.011 The **national** teams' expenses shall be met by the organiser from noon on the day preceding the competitions until the day following the competitions, making a total of 4 nights.

(text modified on 1.02.13).

3.4.012 The organiser shall pay, in addition of the riders, for:
1 attendant for teams of fewer than 3 riders;
2 attendants for teams of 3 to 5 riders;
3 attendants for teams of 6 to 10 riders;
4 attendants for teams of 11 to 15 riders.

He shall provide accommodation and breakfast.

Any teams wishing to stay longer shall do so at their own expense and shall inform the organiser to this effect.

(text modified on 1.01.03; 26.08.04; 25.09.07; 24.01.08).

3.4.013 The Commissaires Panel shall comprise 4 UCI international commissaires including the Chief Commissaire and the Secretary who shall be appointed by the UCI.
The organising National Federation shall designate the starter, the finishing judge and all other commissaires that may be necessary for the efficient control of the races, as well as timekeepers.

(text modified on 1.01.02).

3.4.014 The UCI shall appoint a Technical Delegate.

(text modified on 1.01.02).

3.4.015 The organiser shall meet the expenses of all persons designated by the UCI, but they will be paid by UCI according to usual conditions.

3.4.016 A meeting shall be convened at 6 pm on the eve of the first competition. It shall be attended by all the officials and the Team Leaders. It shall be chaired by the Chief Commissaire in the presence of the UCI Technical Delegate and the persons responsible for organisation.

Prizes

3.4.017 The scale of prizes for the individual classification by race will be established annually by the UCI Management Committee in the financial obligations.

(text modified on 1.01.02).

3.4.018 [abrogated on 1st January 2002].

3.4.019 The prizes shall be paid out by the organiser at the end of each competition to the representatives of the respective teams.

(text modified on 1.01.02).

3.4.020 The three first in each race shall receive from the organiser, respectively, a gold medal (1st place), a silver medal (2nd place) and a bronze medal (3rd place).

The nation obtaining the top classification in the competition shall also receive some work of art from the organiser.

Classification

3.4.021 On completion of each race in each competition, riders shall be awarded the number of points *as per the corresponding scale of article 3.3.010.*

(text modified on 1.01.02; 25.02.13).

3.4.021 bis At the end of each competition, the order of precedence between riders drawing in the general classifications shall be determined according to the greatest number of 1st places, then 2nd places, etc. considering only the placings for which points are awarded.

If they still stand equal, precedence shall be awarded to the rider with the best classification in the most recent event.

(article introduced on 1.10.04).

3.4.022 The general classification of the competition by nation shall be determined by adding the points obtained by the riders of each team in each of the 15 races.

In case of a tie on points, the number of first places shall be taken into account, then the number of second places, and so on.

(text modified on 1.01.02).

3.4.023 The total points obtained by each nation in each competition shall serve, after the last competition of the year, to establish the final general classification by nation.

3.4.024 The UCI shall award the UCI WORLD TRACK CUP trophy for the first nation in the final general classification.

(text modified on 1.01.02).

3.4.025 The UCI shall award a World Cup leader's jersey for the first rider in the final general classification of each event.

Except where article 1.3.055bis, applies, the World Cup leader shall wear his jersey in all track races in the category of which he is the leader and no other race.

(text modified on 26.08.04; 1.10.04; 1.09.05; 30.09.10).

V**Chapter WORLD RECORDS****General comments**

3.5.001 The UCI shall recognise solely World Track Records in the following categories and specialities:

Flying start:

All categories: 200 m and 500 m.

Standing start:

Men: Team Sprint (on 250 m track only), 1 km, 4 km, 4 km team, hour record

Women: Team Sprint (on 250 m track only), 500 m, 3 km, 4 km team, hour record

Junior Men: Team Sprint (on 250 m track only), 1 km, 3 km, 4 km team

Junior Women: Team Sprint (on 250 m track only), 500 m, 2 km, 4 km team

(text modified on 01.01.02; 10.06.05, 24.09.09; 30.09.10; 25.02.13).

3.5.002 The World Record is the exclusive property of the UCI.

The UCI is the exclusive holder of all audio-visual, marketing and other rights relating to any attempt to set a world or any other record. The UCI may surrender those rights on any conditions that it may determine.

(text modified on 1.01.02).

3.5.003 Only the UCI may recognise and confirm a world record.

(text modified on 1.01.02).

3.5.004 The UCI also recognises and confirms Olympic records.

3.5.005 Records may be set during a competition or during a special attempt that shall also be ridden in accordance with the relevant UCI regulations.

A special attempt must be authorized in writing in advance by the national federation of the rider(s). This authorization must reach the UCI no later than one month prior to the attempt.

Specific world record attempts shall not take place during the world championship competitions other than for the hour record or the best hour performance.

(text modified on 1.01.02).

3.5.006 The public and the Press shall be able to attend World Record attempts for their full duration.

The number of spectators and Press personnel may be limited in the interest of sporting performance, subject to prior UCI agreement.

3.5.007 For record attempts outside competition the rider or the team shall take the track alone.

(text modified on 1.01.02).

3.5.008 Records must be set on a UCI-approved track.

Only bicycles admitted by the Track Race Regulations may be used.

A starting block shall be used in all specialities with a standing start, including the hour record.

3.5.009 If the record attempt takes place in a country other than that of the National Federation of the rider, both Federations shall reach an agreement which shall ensure that the attempt may be made under the best possible circumstances, especially with regard to policing services, timekeeping, commissaires and the drug test.

(text modified on 1.01.02).

3.5.010 Any costs incurred by the attempt shall be met by the rider (including the travel and accommodation costs of the international commissaire and the drug-test inspector, the laboratory costs and other UCI expenses).

If the attempt takes place in some other country, the National Federation of that country shall be entitled to be reimbursed any expenses it may have had to incur.

The rider's National Federation shall be held jointly liable for paying costs incurred by the attempt.

Time-keeping

3.5.011 Record attempts shall be electronically timed lap by lap to the nearest thousandth of a second.

3.5.012 Electronic time-keeping of hour record attempts must be accompanied by a system of manual time-keeping. That time-keeping shall be conducted by two timekeepers approved by the National Federation of the country where the attempt takes place.

3.5.013 Recorded times shall be entered on the time-keeping sheets that then have to be signed by the timekeeper that fills them in.

Verification

3.5.014 A record set during a competition shall be confirmed only if a UCI international commissaire has been monitoring the race as member of the Commissaires Panel and signs the report referred to in article 3.5.016.

3.5.015 Any record attempt shall be authorised beforehand by the National Federation of the country where the attempt takes place. The National Federation shall appoint a UCI international commissaire to supervise the attempt. For an hour record attempt, the commissaire shall be appointed by the UCI.

Report

3.5.016 A succinct report specifying the circumstances in which the record has been set shall in all cases be drawn up on the models provide by the UCI. The report shall be immediately written and signed by the UCI international commissaire and by at least one other official present and by the rider(s) who set the record.

See appendix 1

(text modified on 1.01.02).

3.5.017 The international commissaire shall then send the report, with the original time-keeping sheets, to the UCI.

Drug Test

3.5.018 No World Record can be confirmed if the rider in question did not submit to the drug test conducted in accordance with the UCI Anti-doping Examination Regulations at the end of the race. For team events, all team members who have set the new record shall take the test.

The record can be confirmed only on the basis of a certificate issued by the laboratory indicating that the test proved negative.

(text modified on 1.01.02, 18.06.10).

Confirmation

3.5.019 No record shall be confirmed if it does not comply with all applicable provisions.

3.5.020 A record beaten the same day shall not be confirmed.

3.5.021 Records established during World Cup rounds, World Championships and Olympic Games may be confirmed by a certified copy of the official result communiqué, signed by the Chief Commissaire and by the UCI Technical Delegate. In case of disagreement, a request for conformation may be lodged with the Management Committee pursuant to the following articles.

(text modified on 01.01.02; 10.06.05).

3.5.022 Notwithstanding the application of article 3.5.021, a World Record shall be recognised only if confirmed by the UCI.

3.5.023 A request for confirmation shall be lodged by the rider that set the record or by his National Federation. To be considered, the request shall have reached UCI headquarters at the latest one month after the date the record was set.

3.5.024 If the UCI considers that there exist circumstances opposing confirmation, it shall invite the rider or his representative to elucidate those circumstances before taking a decision. If that is not done and if the record is not confirmed, the rider may lodge an appeal with CAS.

(text modified on 1.01.10).

3.5.025 The UCI shall keep an up-to-date list of confirmed world records which it shall publish regularly.

Hour Record

3.5.026 The Hour Record is the greatest distance achieved in one hour on a traditional bicycle, as defined in articles 1.3.006 to 1.3.010 and 1.3.019 of the rules, and as further defined in the following specifications:

- Triangular frame composed of straight, circular section tubes with a minimum diameter of 2.5 cm.
- Traditional style handlebars with an overall width of 50 cm maximum and 34 cm minimum.
- Two wheels of equal diameter, measuring 65 to 70 cm, including tyres.
- Tyre section of a minimum of 16 mm and a maximum of 25 mm.
- Spoked wheels with a minimum of 16 and a maximum of 32 spokes; the spokes may be round, flat or oval provided that none of their cross-sections exceeds 2 mm. (See diagram 1 below).
- Shallow, unelongated, non-profiled rims; shallow rims are understood to be rims whose cross-section fits inside a 2.2 cm square. (See diagram 2 below).
- Other measurements in accordance with those defined in articles 1.3.012 to 1.3.017 (see figure "Measurements") and 1.3.022, 1.3.024 and 1.3.025.

(1) The spokes may be round, flat or oval as long as the width of a cross-section at any point is no broader than 2 mm in any direction.

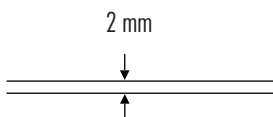

(2) Shallow rims are understood to be rims whose cross-section fits inside a 2.2 cm square.

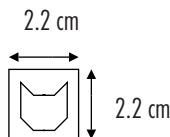

Riders must wear a helmet certified according to international safety standards, intended solely for the purposes of protecting the head, without a visor, and without any devices or shapes added to or moulded into the helmet with the intention of or having the effect of reducing air resistance.

Articles 1.3.026 and 1.3.033 will be strictly applied.

- 3.5.026 bis** The UCI shall recognize solely the best performances on track, in the following categories and specialties:

Men: best performance on 4 km, best hour performance, best hour performance behind derny
Women: best hour performance

(article introduced on 30.09.10).

Best Hour Performance

- 3.5.027** The Best Hour Performance is the greatest distance achieved in one hour on a bicycle conforming to articles 1.3.006 to 1.3.010.

The bicycle shall be submitted to the Equipment Commission for approval 15 days before the date of the attempt.

- 3.5.028** The rider starts from the pursuit line as defined in article 3.6.083.
- 3.5.029** The timekeeper shall, by ringing a bell, indicate the last lap (or the lap during which the hour expires) when the time remaining to ride is less than the average time realised over one lap of the track.
- 3.5.030** The attempt shall terminate when the rider crosses the pursuit line from which he started. The end shall be indicated by a double pistol shot.
- 3.5.031** The distance covered in the hour shall be calculated as follows:

$$D = (L \text{ Pi} \times \text{TC}) + \text{Di C}$$
$$\text{Di C} = \frac{L \text{ Pi} \times \text{TRC}}{\text{TTC}}$$

Where: D = distance covered in the hour
L Pi = length of track
TC = number of complete laps before the last lap
Di C = additional distance
TTC = time of the last complete lap
TRC = time remaining to ride at the beginning of the last lap

- 3.5.032** The distance covered shall be rounded down to the nearest metre. Neither the Hour Record nor the Best Hour Performance may be beaten by less than one metre.
- 3.5.033** If, between the expiry of the hour and the end of the last lap, an incident occurs to prevent completion of the lap, the additional distance shall be calculated on the basis of the time of the lap before last.

Best hour performance behind derny

3.5.034 The best hour performance behind derny is the greatest distance achieved in one hour on a bicycle in compliance with articles 1.3.006 to 1.3.010.

The moped (derny) must comply with articles 3.6.029 to 3.6.051 and the attire of the moped pacers must comply with article 3.6.063. In no case the machine may be fitted with a roll behind the rear wheel.

The bicycle and the moped (derny) shall be submitted to the Equipment Unit for approval at least 15 days before the date of the attempt.

(article introduced on 10.06.05).

3.5.035 The articles 3.5.028 to 3.5.033 of the best hour performance regulation shall apply.

(article introduced on 10.06.05).

VI

Chapter **EQUIPMENT AND INFRASTRUCTURE**

§ 1 Starting Blocks

3.6.001 The starting blocks shall be constructed in order that they are easy to handle and removable from the track surface in 5 seconds maximum. They must be tested and approved by the UCI Technical Delegate or the competition Chief Commissaire.

(text modified on 1.01.02).

3.6.002 The bicycle shall be held in a vertical position, whatever the banking of the track. For that purpose, the starting block shall be fitted with adjustable feet.

3.6.003 The bicycle shall be held firmly by means of a brake that grips the edge of the rear wheel rim.

(text modified on 1.01.02).

3.6.004 The brake shall be adjustable in height so that it can block wheels of different diameters and in width to grip rims of different thickness.

3.6.005 The brake shall release the rear wheel at the moment of the start, so that all competitors start at exactly the same moment.

3.6.006 (N) The brake of the starting block shall be released by the electronic system which simultaneously triggers the chronometer.

§ 2 Motorbikes for motor-pacing

3.6.007 Machines used for training shall comply with the drawing in article 3.6.028.

All the measurements in the drawing are taken from the centre of the rear wheel spindle or from a fixed point on the framework as near as possible to the rear wheel spindle (this point being clearly defined) and from the ground.

3.6.008 The machines shall be single track, of unspecified make and model and shall be driven by a single driver.

3.6.009 The engine and the frame shall correspond exactly to standards of the original model as defined by the constructor.

Engine

3.6.010 The engine capacity shall be 500 cc. minimum and 1000 cc. maximum.

3.6.011 These engines shall be of the single or double cylinder, vertical type. Flat Tween engines are forbidden.

Frame

3.6.012 The machine shall be of a commercially available type. The width of the framework shall be 350 mm. maximum. The rear shock absorber shall be removed and replaced by a round tube of the same diameter as the tubes of the frame, that is to say 30 mm.

Saddle

3.6.013 The saddle, of a commercially available type, shall be 300 mm wide and 350 mm long. The position of the pacer being what is referred to as "standing", the saddle shall be set tipped forward. The saddle may in no case be modified; the addition of cushions, leather, cloth, etc., which might afford additional shelter, shall be absolutely forbidden. The front outer edge of the saddle shall be set at 800 mm from the ground and 250 mm forwards of a perpendicular passing through the rear wheel spindle. The rearmost point of the saddle shall be set at 1030 mm from the ground and touching that same perpendicular passing through the rear wheel spindle.

Wheels

3.6.014 The wheels shall comprise metal rims and commercial spokes. They shall be of a maximum diameter of 650 mm. Tyres: front wheel 350 x 19, rear wheel 350 or 400 x 19.

3.6.015 A reliable brake shall act on the front wheel. The brake acting on the rear wheel shall serve merely to slow down the bicycle.

Handlebar

3.6.016 The handlebar shall be made in one piece. Its width to the rear shall be 700 mm maximum (width taken at the exterior of the grips).

3.6.017 The two grips shall be of the same height. The height above the ground shall be 1000 mm minimum and 1050 mm maximum. The height may be adjustable within those limits.

3.6.018 The rear extremity of the grips of the handlebar shall pass through the same perpendicular to the ground as that passing through the foremost point of the saddle, that is to say 250 mm forwards of the rear wheel spindle.

3.6.019 No lever or any other controlling device may, in its operating position, project beyond the rearmost extremity of the grips. Leather devices, levers or hooks and other accessories fixed to the grips shall be absolutely forbidden.

3.6.020 Each pacer shall hold his handlebar with both hands. Driving with one hand alone shall be authorised only when adjusting the engine or in cases of danger.

Footrests

3.6.021 Footrests shall be fixed to the frame tubes to the left and right. Each footrest shall comprise a "sole" and a sheet metal toe-cap.

- 3.6.022** The sole of the footrest shall comprise a flat plate, whose dimensions shall be 120 mm wide by 240 mm long overall. It shall be rounded into a semicircle to the rear. The toe-cap shall measure 80 mm to the fore and 200 mm to the rear; it shall be welded around the sole.
- 3.6.023** The centre of the footrest shall align on the same perpendicular to the ground as that of the foremost point of the saddle and rearmost points of the handlebar. The front of the footrests shall be permanently fixed at 240 mm from the ground.
- 3.6.024** The rear shall be adjustable. However, the both footrests shall always be set to the same height for all motorbikes used in any given competition.
- 3.6.025** The overall width between the outer edges of the two footrests shall be 650 mm maximum.

Roll

- 3.6.026** Each machine shall, behind the rear wheel, be fitted with a roll the tube of which shall be of a maximum diameter of 35 mm. The width of the roll shall be 600 mm. The centre of the roll spindle shall be set 335 mm from the ground.
- 3.6.027** The roll shall be fixed to the rear of the frame using cranked flat irons; the irons shall be 35 mm wide by 6 mm thick. Two distance pieces hold the roll in the correct position; these distance pieces shall also be made of flat iron strip, 35 mm wide by 6 mm thick. The distance between the rear-wheel spindle and the roll shall be adjustable in 50 mm steps from a minimum of 600 mm to a maximum of 800 mm.

3.6.028

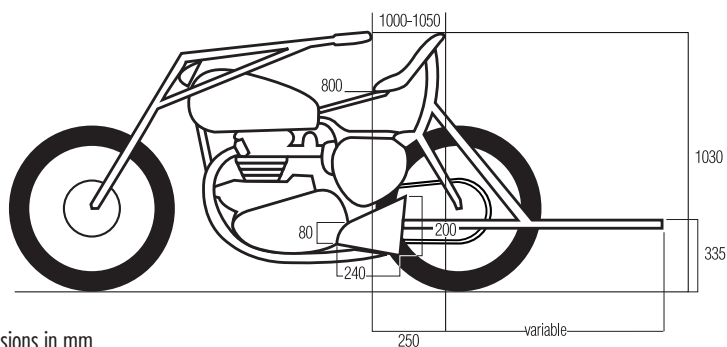

Dimensions in mm

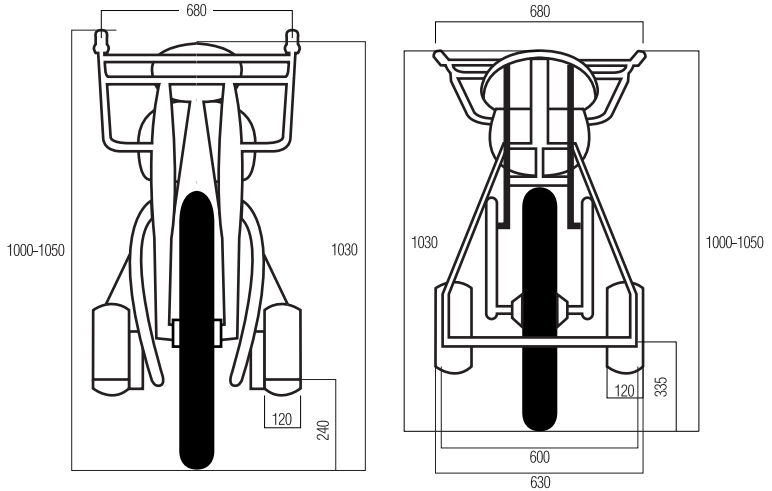

Dimensions in mm

§ 3 Mopeds

- 3.6.029** As the moped is meant to replace human pacing, the shelter that it affords shall be fundamentally the same as that afforded by a bicycle.
- 3.6.030** No part of the moped may be surrounded by leather, rubber, felt or other materials that could act as an artificial wind-break.
- 3.6.031** The moped shall comply strictly with the following provisions.

Engine

- 3.6.032** The machine shall be fitted with an engine of 100 cc maximum which will serve merely to help the pacer pedal.
- 3.6.033** The use of a free wheel shall be absolutely forbidden; a fixed front chain-wheel shall be mandatory.

Frame

- 3.6.034** The machine shall be a single-track one-seater.
- 3.6.035** The machine, including the front fork, shall be made of tubing, similar in every respect to that used for the construction of an ordinary bicycle.
- 3.6.036** The height of the frame with a rake similar to that of a bicycle shall be between 560 mm minimum and 580 mm maximum (distance taken from the chainset spindle to the axis of the upper tube).

3.6.037 The height of the chainset spindle above the ground shall be from 230 mm minimum to 290 mm maximum.

3.6.038 The width of the chainset (including pedals) shall be 380 mm maximum.

Saddle

3.6.039 The saddle shall be of a commercially available racing model in leather; it shall measure 300 mm maximum in length by 150 to 180 mm in width. The saddle shall overhang the frame by an equal distance on each side.

3.6.040 The saddle may not be in any way modified. The addition of cushions, leather, cloth, etc. to provide additional shelter shall be absolutely forbidden.

3.6.041 The foremost tip of the saddle peak shall be placed:
(a) 450 mm from the axis of the steering expander tightening bolt on tracks of 200 metres and more;
(b) 400 mm from the axis of the steering expander tightening bolt on tracks of less than 200 metres.

3.6.042 The height of the rear of the saddle above the ground shall be 870 mm minimum.

Handlebar

3.6.043 The handlebar shall be made in one piece and be a maximum 500 mm across (distance measured at the extremities of the grips).

3.6.044 The handlebar shall be 30 mm below the level of the steering expander tightening bolt which shall itself be 900 mm above the ground. The handlebar grips shall therefore be 870 mm from the ground (distance measured from the top of the grips).

For tracks of less than 200 m, the handlebar grips shall be 920 mm from the ground (distance measured from the top of the grips).

3.6.045 The rearmost points of the handlebar shall be 200 mm maximum to the rear of the steering expander tightening bolt. The tube ends shall be filled and the grips may be clad in insulating tape. Rubber grips shall be absolutely forbidden.

Wheels

3.6.046 The wheels shall comprise metal rims. They shall be of 650 mm diameter and fitted with a 55 mm section tyre.

3.6.047 The rear wheel shall be of 700 mm diameter and shall be fitted with a 42 mm section tyre.

Tank

3.6.048 The tank, being cylindrical, measuring 180 mm in diameter by 265 mm in length and taking a petrol (gasoline) and oil mixture, shall be fixed to the steering pin.

Mudguard

3.6.049 The mudguard shall be made of steel.

3.6.050 The width of the rear mudguard shall be 70 mm maximum. It shall be made as a single piece and form a protective shield on both sides. Its foremost point shall be fixed to the frame tubes and its rearmost point to the rear wheel spindle. It shall be 140 mm high. The distance between the steering expander button and the perpendicular with the ground passing through the rear end of the mudguard shall be 1250 mm. The distance between the rear of the saddle and the perpendicular with the ground, passing through the rear end of the mudguard, shall therefore be 500 mm minimum.

3.6.051

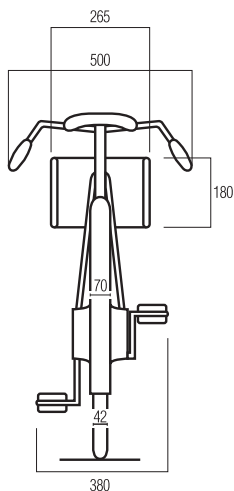

§ 4 Attire of motor-pacers

3.6.052 Motor-pacers shall wear a leather jacket of the following dimensions:

- length of the back without collar 67 cm
- width of the back at sleeve level 45 cm
- width of chest at sleeve level 35 cm
- circumference of chest taken under the arms 120 cm
- circumference of the bottom of the jacket 120 cm
- length of sleeve from shoulder seam to elbow 60 cm
- circumference of sleeve around biceps 40 cm
- circumference of sleeve around wrist 28 cm
- circumference of collar 44 cm
- height of collar 3.5 cm

3.6.053 The collar shall be closed by two hooks. The jacket shall zip up the back (from the bottom up).

- 3.6.054** The jacket may not be opened during the race or in any way modified for the purpose of favouring a rider.
- 3.6.055** Pacers shall wear leather trousers, without gaiters, and of the following dimensions:
- length of outer leg 94 cm
 - length of inner leg 68 cm
 - circumference of waist 102 cm
 - circumference of hip across the buttocks 114 cm
 - circumference of thigh 72 cm
 - circumference above the knee 48 cm
 - circumference below the knee 36 cm
 - circumference of calf 40 cm
 - circumference of ankle 30 cm
- 3.6.056** The leather trousers shall also have a 22 cm wide cloth belt with, to the rear and pointing downward, a rubber tail 48 cm long by 9 cm wide.
- 3.6.057** The trousers shall have no openings other than on the outside of each leg, running 40 cm up from the ankle. These openings shall be secured by zip fasteners closing from the top down.
- 3.6.058** The trousers shall be held up by straps crossing and secured behind with rubberised loops.
- 3.6.059** Under their leather suits, pacers shall wear only a light, tight-fitting jersey and cyclist's racing shorts. The jacket must close without straining the seams or the zipper. The jerseys shall be of equal thickness throughout and may in no way be padded. There may be no openings in underclothes and jerseys.
- 3.6.060** Pacers may wear only one pair of socks. They must be held up by suspenders.
- 3.6.061** Only normal-size, fully enclosed leather boots shall be permitted.
- 3.6.062** A rigid helmet shall be worn at all times during racing and training. It may not be unstrapped or removed during the race. Ear-flaps, which may be fixed to the helmet, may not protrude by more than 1 cm by 3 cm.

§ 5**Attire of moped pacers**

- 3.6.063** All pacers shall wear the same attire:
- a) a light, short-sleeved pullover
 - b) a clinging rider's jersey with patch pockets; long sleeves shall be allowed; the commissaires may permit the wearing of a supplementary racing jersey
 - c) shorts (tight black descending to mid-thigh)
 - d) special black shoes known as «cyclists' shoes» and all-white or all-black socks
 - e) a pair of racing gloves or a pair of normal unlined gloves but not gauntlet gloves
 - f) a moulded shell hat of the type worn by stayers; it may have neither ear-flaps nor leather, felt or cloth straps that could act as artificial wind-breakers.

**TECHNICAL SPECIFICATIONS AND VELODROMES
HOMOLOGATION:****§ 6****Velodromes**

3.6.064 Track events included on the UCI International calendar must be held at a UCI-homologated velodrome. Exceptionally, special dispensations may be granted by UCI for Velodromes in use prior to 2001.

Track events included on national calendar may be held at a nationally homologated or a UCI-homologated velodrome.

3.6.065 A velodrome may not be homologated by the UCI unless it meets the following conditions.

3.6.066 The stability and resistance of the materials and fixings which make up the structure of the velodrome shall meet the legislation regarding construction and safety of the country in which it is built and shall take account of specific geological and climatic conditions.

These elements, along with general compliance of the construction and construction materials with technical standards and good practice, remain the exclusive responsibility of the owner, contractor, architect, consulting engineer, proprietor, operator, user, organiser or others, in accordance with local legislation or regulations. The UCI is exempt from any responsibility in this regard.

Homologation of the velodrome by the UCI rests not on the technical and structural characteristics of the velodrome, but solely on the compliance of its external features with the provisions of the present paragraph at the time of the inspection. The UCI is not liable for any faults or defects which lie outside the scope of such homologation, or which appear or come to light subsequent to the inspections on which such homologation is based.

(text modified on 1.01.02).

TRACK GEOMETRY**Form**

3.6.067 The inner edge of the track shall consist of two curves connected by two parallel straight lines. The entrance and exit of the bends shall be designed so that the transition is gradual.

The banking of the track shall be determined by taking into account the radius of the curves and the maximum speeds achieved in the various disciplines.

Length

3.6.068 The length of the track must lie between 133 metres and 500 metres inclusive.

The length of a track shall be such that a whole number of laps or half laps shall give a distance of precisely 1 kilometre, with a tolerance of + 5 centimetres.

For the *World Championships and the Olympic Games* the length must be 250 metres. In the interest of the development of track cycling, the UCI may grant a special dispensation for Velodromes already in use.

(text modified on 1.01.02, 24.09.09).

3.6.069 The length of the track shall be measured 20 cm above the inner edge of the track (the upper edge of the blue band).

Width

3.6.070 The width of the track must be constant throughout its length. Tracks approved in categories 1 and 2 must have a minimum width of 7 metres. Others tracks must have a width proportional to its length of 5 metres minimum.

(text modified on 1.01.02).

Blue band

3.6.071 A rideable area sky-blue in colour known as the "blue band" must be provided along the inside edge of the track. The width of this band must be at least 10% of the width of the track and its surface must have the same properties as of the track. No advertising inscription is permissible in this area.

With the exception of mounted riders, no person or object may be on the blue band while one or more riders are on the track.

(text modified on 1.01.02).

Safety zone

3.6.072 Immediately inside the blue band there shall be a prepared and marked safety zone. The combined width of the blue band and the safety zone shall be at least 4 metres for tracks of 250 metres and over, and 2.5 metres for tracks shorter than 250 metres.

With the exception of the commissaires, mounted riders or other persons authorised by the chief commissaire, no person or object (including starting blocks) may be inside the safety zone when a rider is on the track.

(text modified on 1.01.02; 26.08.04).

3.6.072 bis A fence, of a construction ensuring the adequate safety for riders at a height of at least 120 cm, must be erected on the inner edge of the safety zone except if the following conditions are met:

- 1) there are no height difference or abrupt gradient between the safety zone and the track centre or within the track centre, and
- 2) inside the safety zone and at a distance of 10 m of the blue band, is no unauthorized person or object in accordance with article 3.6.072.

The fence must be transparent and in no circumstances may any advertising boards be attached to it.

In places where the level of the track proper is more than 1.5 m. higher than the actual track centre, additional protective measures such as nets, panels, or the like, shall be erected in order to prevent athletes being subjected to injury.

Any gates provided in the fencing must be fitted with simple and reliable fastenings. They must be kept closed while racing and training is in progress.

(text modified on 1.01.02; 26.08.04).

Profile

3.6.073 At any point on the track, a cross section of the track surface must present a straight line. In the bankings, the inner edge should have a curved transition onto the blue band.

3.6.073 bis At any point of the track or safety zone surface, a perpendicular distance from the surface of at least 3 metres must be guaranteed free of any obstacle.

(text modified on 1.01.02).

Surface

3.6.074 The surface of the track shall be completely flat, homogenous, non-abrasive. The tolerance of flatness for the track surface shall be 5 mm over 2 metres. The coating shall be uniform in all its aspects over the entire track surface. Coatings intended to improve the rolling qualities of one part of the track only are not permitted.

(text modified on 1.01.02).

3.6.075 The surface colour of the track must leave the track marking lines clearly visible.

MARKING

Painting

3.6.076 Any demarcation, line, advertisement or other marking on the track must be applied with a paint or product which is non-slip and which does not alter the adhesion properties, consistency or homogeneity of the surface.

(text modified on 1.01.02).

3.6.077 Advertisements on the track surface must be placed above the stayers' line within a longitudinal band between 50 cm of the stayers' line and 50 cm from the fence (the outside edge of the track). No advertisement may be placed within 1m either side of the pursuit and the 200 m lines, or within 3 m either side of the finish line, measured from the outside edge of the white band.

(text modified on 1.01.02).

- 3.6.078** The longitudinal lines covered by articles 3.6.079 to 3.6.081 shall have a constant width of 5 cm. The perpendicular lines covered by articles 3.6.082 to 3.6.084 shall have a constant width of 4 cm.

Longitudinal markings:

Measuring line

- 3.6.079** A line, in black on a light background or in white on a dark background, known as the “measuring line” shall be drawn at 20 cm from the inside edge of the track, numbered every 10 metres and marked every 5 metres. The measurement of the measuring line shall be taken on its inside edge.

Sprinters’ line

- 3.6.080** A red line, known as the “sprinters’ line” shall be marked out 85 cm from the inner edge of the track.

The distance is to be measured to the inner edge of the red line.

(text modified on 21.01.06).

Stayers’ line

- 3.6.081** A blue line, known as the “stayers’ line” shall be drawn at one third of the total width of the track or 2.45 m (whichever is the greater) from the inner edge of the track.

The distance is to be measured to the inner edge of the blue line.

(text modified on 21.01.06).

Perpendicular markings:

Finish line

- 3.6.082** The finish line shall be situated towards the end of one of the straights but at least a few metres before the entrance of the banking, and in principle in front of the main grandstand.

It shall be marked by a perpendicular black line 4 cm in width at the centre of a white band 72 cm in width.

The finish line marking on the track shall continue up to the top of the flat surface of the fencing.

200 metre line

- 3.6.083** A white line shall be drawn across the track 200 metres before the finish line, from which point the times will be taken for sprint events.

Pursuit lines

- 3.6.084** Two red lines half the width of the track in length, perpendicular to the track and precisely in line with one another, shall be drawn at the precise midpoint of each of the straights to mark the finish points for pursuit events.

EQUIPMENT

Access tunnel

- 3.6.085** The track centre, which is located inside the safety zone, must be obligatorily accessible via one or more tunnels.

Riders' area

- 3.6.086** Within the track centre areas must be provided for riders to change and warm up, as well as waiting areas near the pursuit and finish lines.

Fencing

- 3.6.087** The outside edge of the track must be surrounded by a safety fence to protect riders and spectators. It must be stable and solidly mounted, with an overall height of at least 90 cm. The inside part must be completely smooth and unbroken to a height of at least 65 cm above the track. It must present no protrusions or projecting parts.

At the places where the area outside the track is at a level 1.5 metres or more below the outside edge of the track surface, additional protective measures (nets, panels, etc.) must be provided to reduce the risks resulting from riders accidentally leaving the track.

The colour of the outside fencing must contrast clearly with that of the track.

Any gates provided in the outside fencing must open outwards and be fitted with simple and reliable fastenings. They must be kept closed while racing and training is in progress.

(text modified on 1.01.02).

Miscellaneous

- 3.6.088** A lap counter clearly visible to riders and spectators and a bell audible through-out the track area shall be placed near the finish line.

For pursuit events, bells and lap counters shall be placed on both side of the track, near the pursuit lines, in accordance with article 3.2.066.

(text modified on 1.01.02).

- 3.6.089** A timing system including starting blocks, contact bands and an electronic display (times to the thousandth of second, laps, points, etc.), a photofinish or video-finish system to assist in judging finishes, and a general public address system clearly audible throughout the entire velodrome area must be provided.

Contact strips must be laid over the width of the track or an acceptable timing detector such as light beams installed.

(text modified on 1.01.02).

Lighting

3.6.090 Suitable lighting must be provided which meets the safety conditions into force in that country.

The lighting system must be supplemented by an emergency lighting system operating independently of mains electricity, capable of providing an intensity of at least 100 Lux for 5 minutes which must be effective instantaneously.

During training sessions without spectators, vertical lighting must be at least 300 lux. During competitions at least 1400 Lux is required for the Elite World Championships and the Olympic Games (category 1 velodromes), at least 1000 Lux for category 2 velodromes and at least 500 Lux for category 3 and 4 velodromes.

(text modified on 1.01.02).

ACCOMMODATION FOR OFFICIALS

Finish judge's podium

3.6.091 A podium must be provided for the judge at the finish, located in the track centre in line with the finish line.

Box for the Commissaires Panel

3.6.092 Adequate accommodation must be provided for the commissaires on the track centre adjacent to the finish line.

(text modified on 1.01.02).

Box for the referee:

3.6.093 Provision must be provided for the judge-referee on the outside of the track. It must be in a quiet, isolated location overlooking the track with an unimpeded view, e.g. at the top of the stand above the finish line. During competitions there must be a radio link between the referee and the other commissaires, including the starter and the president of the Commissaires Panel.

Category 1 and 2 velodromes must also provide the referee with a video filming system with slow-motion replay which enables all the shots of the race to be reviewed.

Centre podium for the starter:

3.6.093 bis In the middle of the track center in line with the pursuit lines, a podium must be provided for the starter. It must have an area of between 3 and 4 m² and must be raised above track level.

(text modified on 1.01.02).

HOMOLOGATION OF VELODROMES

3.6.094 At the time of their homologation, velodromes shall be classified into four categories on the basis of the technical quality of the track and installations. The category determines the level of competition which can be organised in the velodrome, as shown in the following table:

CATEGORY	HOMOLOGATION	LEVEL OF EVENTS
1	UCI	Elite World Championships and Olympic Games.
2	UCI	World Cups Continental Championships Junior World Championships
3	UCI	Other international events
4	NATIONAL FEDERATION	National events

3.6.095 Category 1 and 2 tracks must meet the following criteria (calculated for maximum safe speeds in the range 85 km/h up to 110 km/h):

Length of the track	250 m	285.714 m	333.33 m	400 m
Radius of bends	19-25 m	22-28 m	25-35 m	28-50 m
Width	7-8 m	7-8 m	7-9 m	7-10 m

Other tracks must be designed to guarantee a minimum safe speed of at least 75 km/h.

(text modified on 1.01.02).

3.6.096 Requests for homologation shall be submitted to the UCI by the national federation of the country in which the velodrome is located.

3.6.097 The request for homologation must be sent to the UCI at least 2 months before the planned inspection date. It must be accompanied by a technical file complying with the UCI's standard model.

The UCI may require any additional document or information.

(text modified on 1.01.02).

3.6.098 The national federation shall organise the inspection of the velodrome in the presence of a specialist responsible for carrying out the regulation measurements under the direction of a UCI delegate. On this occasion a test of the track by a group of riders must be carried out.

All expenses incurred in connection with the inspection of the velodrome are to be covered by the applicant, the national federation being held jointly liable.

The costs of the UCI delegate are covered in accordance with the conditions specified in the UCI financial obligations in force.

(text modified on 1.01.02).

3.6.099 A detailed inspection report shall be drawn up by the UCI delegate and countersigned by the persons responsible for the measurement of the track and a representative of the national federation.

3.6.100 Should the UCI consider that there are aspects which might lead to homologation being withheld, it shall invite the parties requesting homologation to justify these aspects before a decision is reached. Failing this, and in the event that homologation for the velodrome is withheld, the Federation concerned may appeal to CAS.

(text modified on 1.01.10).

3.6.101 Any changes to or renovation of the facilities following the inspection of the velodrome shall nullify the homologation. New homologation is subject to the procedure described in articles 3.6.097 and following.

(text modified on 1.01.02).

VII

Chapter TRACK TEAMS

[chapter introduced on 31.05.04].

§ 1

Identity

3.7.001 A Track Team (TT) is an entity, comprising at least three riders and its employer, set up for the purpose of participating in international track events.

(text modified on 30.03.09).

3.7.002 The Team shall comprise all the riders employed by the same employer, the employer itself, the sponsors and all the other persons contracted by the employer and/or the sponsors for the functioning of the team (Team Manager, Coach, Soigneur, Mechanic etc.). It shall be designated by a special name and be registered with the UCI as provided in these regulations.

3.7.003 The track teams may take part in the following speciality events:

- Sprint
- Keirin
- 1000/500 m time trial
- Team sprint
- Individual pursuit
- Points race
- Scratch
- Madison
- Team pursuit

3.7.004 Sponsors shall be persons, companies or bodies which contribute to the funding of the Team. Of these sponsors, no more than two may be designated as the principal partners of the Team. Should neither of the two principal partners be the employer of the team then the employer may be only a person or body corporate, whose sole commercial income is derived from advertising.

3.7.005 The principal partner(s) and the employer shall commit themselves to the Team for a whole number of calendar years.

3.7.006 The name of the Team must either be that of the company or brand name of the principal partner or that of one or both of the two principal partners, or the name of its paying agent.

Upon specific request, the UCI may authorise another designation which is linked to the team project. The UCI may refuse the team's registration because of a resemblance of the name of a new team, its paying agent or its principal partners which is likely to create confusion with another team.

(text modified on 1.10.11).

3.7.007 No two Teams, their principal partners or employers, may bear the same name. Should application for a new and identical name be simultaneously made by two or more Teams, priority shall be given to the Team which has used the name for the longer or longest time.

3.7.008 The Team must be affiliated to a national federation, member of the UCI.

(text modified on 30.09.10).

§ 2 Legal and Financial Status

3.7.009 The employer of riders forming a Team shall be a person(s)/corporation(s) legally entitled to engage personnel. It shall sign contracts with the riders.

3.7.010 The principal Partner(s) of the Team, other than the employer, shall be held jointly and knowingly severally liable for the payment of 3 months salary in case of default by the employer as well as the financial obligations chargeable to the team, towards the UCI and the national federations, fines included.

§ 3 Registration with UCI

3.7.011 Each year, Teams must register with the Union Cycliste Internationale.

3.7.012 Teams shall, at the same time, register their riders.

3.7.013 Teams shall communicate their list of staff and riders 15 days prior to the UCI track individual classification period start, for verification and registration.

On the list for each Team the following must be indicated:

1. the exact name of the Team.
2. the complete contact details (address, e-mail, telephone and fax numbers) to which all communications for the Team can be sent.
3. the names and addresses of the principal partners, the employer, the general manager, the team manager and the assistant team manager
4. the surnames, first names, addresses, nationalities and dates of birth of the riders, the dates and numbers of their licenses and the authority that issued them.
5. Copies of contracts between the TTT and the respective riders.

3.7.014 Article 3.7.013 shall also apply to any amendment to the list. Such amendments shall immediately be submitted by the Teams to the UCI for approval.

3.7.015 Only Teams on the registered list of the UCI may receive benefits such as those listed in article 3.7.019.

- 3.7.016** By their annual registration with the UCI, Teams and especially the employers and sponsors shall undertake to respect the Constitution and Regulations of the UCI and their respective National Federation and to participate in cycling events in a loyal and sporting manner. The employer and principal partners shall be held jointly and severally liable for all the financial commitments of the Team to the UCI and the National Federations, including any relevant fines.
- 3.7.017** The registration of the Team with the UCI shall involve a registration fee that the Team shall pay prior to 1 month after the current UCI track individual classification period start. The amount shall be set annually by the UCI Management Committee.
- 3.7.018** With their registration application, each team must submit to the UCI a colour graphic design of their Team jersey, complete with sponsor logos.
- 3.7.019** Those Teams registered with the UCI will receive the following benefits:
1. Inclusion on the UCI Track Team Ranking.
 2. Information services and publications in addition to the regular distributions.
 3. Direct entry services for major UCI events.
 4. Preferred pricing, where negotiated, for accommodations and food at World Cup events.

§ 4 Teams and Riders

- 3.7.020** The team shall be the totality of track team riders to take part in events as specified in article 3.7.003.
- 3.7.021** The total number of riders per Team shall not be greater than 10.
- 3.7.022** A rider shall not enter into any commitment with an organiser, whomsoever that organiser may be, with a view to participating in a race, without having firstly obtained the agreement of his employer or of the employer's delegate. That agreement shall be considered to have been granted if, on being duly requested, the employer has not replied within ten days.

§ 5 Contract of Employment

- 3.7.023** A rider's membership of a Team shall be subject to a contract which must at least contain the stipulations of the standard contract presented in article 3.7.029. It does not include bonus/incentive programs, race schedules, equipment provisions and other details. These are subject to negotiations between the employer and the rider(s).
- 3.7.024** Any clause concluded between the rider and the employer that clearly impinges on the basic rights of the rider as provided for in the UCI regulations shall be considered null and void.
- 3.7.025** Any contract between a Team and a rider shall be drawn up in triplicate at least. One original copy shall be forwarded to the UCI.

§ 6 End of Contract

3.7.026 On the expiration of the foreseen term of the contract, the rider shall be free to enter the service of some other employer. No system of transfer fees shall be permitted.

§ 7 Dissolution of a Track Team

3.7.027 A Track Team shall announce its dissolution or the end of its activity or its inability to respect its obligations, as soon as possible to the riders, to its other members, to the UCI and its National Federation.

Once this announcement has been made, riders shall be fully entitled to contract with third parties for the following season or for the period starting at the moment announced for the dissolution, the end of activities or the inability to perform.

§ 8 Penalties

3.7.028 Should a Team, as a whole, fail or cease to meet all the conditions of the relevant UCI regulations, it may no longer participate in cycling events.

§ 9 UCI Model Contract Between a Rider and a Track Team

3.7.029 Between the undersigned,

(name and address of employer)

employer of the Track Team (name of the Track Team), affiliated by the (name of the National Federation) and whose principal partners are:

1. (name and address) (if appropriate, the employer)
2. (name and address)

hereafter called «the Employer»,

ON ONE PART

And: (name and address of the rider)

born in on

nationality

holder of a licence issued by

hereafter called «the Rider»

ON THE OTHER PART

Do hereby recall that:

- The Employer employs a team of cyclists who, forming the (name of the Team) and under the direction of Mr. (name of the Team Manager), participate in track events governed by the Regulations of the International Cycling Union;
- The Rider wishes to join the (name of the Team)
- Both parties are acquainted with and declare that they will abide wholly by the UCI Constitution and Regulations, and those of its affiliated National Federation.

This having been established, it is hereby agreed as follows:

ARTICLE 1 - Engagement

The Employer shall engage the Rider, and the Rider shall agree to be engaged as a Track rider.

The participation of the Rider in events in other disciplines shall be agreed upon by the Parties case by case.

ARTICLE 2 - Duration

The present contract shall be concluded for a fixed period commencing on.... and expiring on....

ARTICLE 3 - Remuneration

The Rider shall be entitled to an annual gross salary of.... This remuneration may not be lower than the legal minimum wage or, where there is no legal minimum, than the usual salary that is paid or should be paid to full-time workers employed in the country whose National Federation issued the Rider's licence or in the country where the Team has its head office, whichever the higher.

If the duration of that contract is to be less than one year, the Rider shall, over that period, earn at least the full annual salary provided for in the preceding paragraph, less the contractual salary that he would have been able to earn, as a rider with professional status, with some other employer in the course of the year preceding the final date of the present contract.

This provision shall not apply if the present contract is extended.

ARTICLE 4 - Payment of remuneration

1. The Employer shall pay the salary referred to in article 3 above in at least four instalments, at the latest on the last working day of each three-month period.
2. Should the Rider be suspended under the terms of the UCI Regulations or those of one of its affiliate Federations, he/she shall not be entitled to the said remuneration referred to in article 3 for the part of the suspension exceeding one month.

3. Should the Employer fail to pay to the net the remuneration referred to in article 3, the Rider shall, without summoning the Employer to make payment, be fully entitled to the following extra benefits:
 - (a) 5% interest for each of the five working days in arrears starting with the fourth day,
 - (b) and thereafter, an 1% interest for each weekday.The total increase may not exceed 50% the amount due.

ARTICLE 5 - Insurance

The employer shall provide the rider with an appropriate insurance to ensure a reasonable allowance in the event of an unforeseen injury or illness which affects the rider's ability to fulfil the competition aspects of his/her contractual obligations.

ARTICLE 6 - Premiums and prizes

The Rider shall be entitled to premiums and prizes won during cycling competitions in which he/she participated for the Team, in accordance with the Regulations of the UCI and its Affiliated Federations. Premiums and prizes shall be paid as promptly as possible, but at latest on the last working day of the month following that in which said premiums and prizes were won.

ARTICLE 7 - Miscellaneous Obligations

1. The Rider may not, for the duration of the present contract, work for any other Track Team or advertise for any other sponsors than those belonging to the (name of the Team), except in such cases as are provided for in the Regulations of the UCI and of its affiliated Federation.
2. The Employer hereby undertakes to allow the Rider properly to perform his occupation by providing him with the necessary equipment and apparel and by permitting him/her to participate in a sufficient number of cycling events, either as a member of the team or individually.
3. The Rider may not participate individually in a race without the express agreement of the Employer. The Employer shall be deemed to have given its agreement if it has not replied within a period of ten days from the date of the request. In no case may the Rider take part in a race within any other structure or a mixed team if the (name of the Team) has already entered for that race.

In case of a national selection, the Employer shall be required to permit the Rider to participate in preparatory races and programmes decided upon by the National Federation. The Employer shall authorise the National Federation to give the Rider any instructions it deems necessary in connection with and for the duration of the selection provided that it does so solely in connection with sporting matters, in its own name and on its own behalf.

In none of the aforementioned cases shall the Contract be suspended.

ARTICLE 8 - Transfers

On the expiry of the present contract, the Rider shall be entirely free to sign a new contract with another employer, subject to the provisions of the UCI Regulations.

ARTICLE 9 - End of contract

Notwithstanding the legislation governing the present contract, it may terminate before expiration, in the following cases and on the following conditions:

1. The Rider may terminate the present contract, without notice nor liability for damages:
 - (a) if the employer be declared bankrupt, insolvent or goes into liquidation.
 - (b) if the employer or a principal partner withdraw from the Team and the continuity of the Team is not guaranteed or else if the Team announces its dissolution, the winding up of its activities or its inability to meet its commitments; if the announcement be made for a given date, the Rider shall perform the contract until that date.
2. The Employer may terminate the present contract, without notice or liability for damages, in the case of serious defaulter on the part of the Rider and of the suspension of the Rider under the terms of the UCI Regulations for the duration of the present contract remaining to run. Serious defaulter is considered, in particular, refusal to participate in cycling races, despite being constantly summoned to do so by the Employer.
If need be, the Rider shall have to prove that he was in no state to participate in a race.
3. Either party shall be entitled to terminate the present contract, without notice or liability, should the Rider be rendered permanently unable to exercise the occupation of professional cyclist.

ARTICLE 10 - Unreasonable demand

Any clause agreed upon between the parties that runs counter to the terms of the UCI Model Contract between a rider and a Team and/or to the provisions of the UCI Constitution or Regulations and which would in any way restrict the rights of the Rider shall be null and void.

ARTICLE 11 - Arbitration

Any dispute between the Parties arising from the present Contract shall be submitted to arbitration, to the exclusion of the courts, by the UCI arbitral board.

Made in _____ on _____

in as many copies as required by the legislation applicable to the present contract, that is to say,..... plus one copy to be sent to the UCI.

The Rider _____ The Employer _____

Approved for joint and several liability for three (3) months salary payment

Principal Partner _____
of the Track Team _____
Principal Partner _____
of the Track Team _____

(text modified on 1.01.10).

VIII

Chapter CALENDAR

General observations

3.8.001 Track events are entered on the calendars in accordance with their classification and criterias as per articles 3.8.003 and 3.8.005.

The UCI Management Committee allocate a classification in the international calendar to each event in accordance with the criteria which it shall draw up, taking into account the criterias set in article 3.8.003.

(text introduced on 1.01.04).

3.8.002 Without prejudice to the provisions of article 1.2.014, if an event registered in one of the classes 1 to 3 as specified by article 3.8.003 is not run without UCI clearance, it shall be relegated to the next lower class for the following year, unless it is already in class 4.

(text modified on 1.01.04; 26.08.04).

World Calendar

3.8.003 Type of event	Criteria
Olympic Games	- As per the regulations for cycling events at the Olympic Games
<i>World Championships</i>	- <i>As per World Championships regulations</i>
World Cup legs	- As per articles 3.4.004 to 3.4.007
Continental Championships	- See article 3.8.004
Regional Games	
Class 1	- Minimum 5 participating nations - Events for Men Elite - Events for: Junior (M/W), U23 (M/W), Women Elite or Para-cycling (Minimum 3 categories) - Minimum 5 competitions*
Class 2	- Minimum 4 participating nations - Events for Men Elite - Events for: Junior (M/W), U23 (M/W), Women Elite or Para-cycling (Minimum 2 categories) - Minimum 3 competitions*
Class 3	- Minimum 3 participating nations - Events for Men Elite - Events for: Junior (M/W), U23 (M/W), Women Elite or Para-cycling (Minimum 1 category) - Minimum 2 competitions*

* Competition = event from the Elite World Championships programme, organised in a category.

(text introduced on 1.01.04; modified on 1.10.13; 3.03.14).

3.8.004 To be able to be registered on the International Calendar, the Continental Championships have to guarantee participation of riders of at least 6 federations of that continent, exception being where the Continental Confederation does not have 6 federations.

(text introduced on 1.01.04).

National Calendars

3.8.005 Type of event	Participation
National Championships	Governed by National Federations
Other events	Governed by National Federations

(text introduced on 1.01.04).

IX

Chapter **MASTERS**

(chapter introduced on 10.06.05).

Participation in the track races of the UCI World Masters Championships

3.9.001 All 35 years old and older riders holding a license shall be entitled to participate in the UCI World Masters Championships, except the following:

- I. Any rider who was a member of any track team registered with the UCI either in the current year or in the current season. The season is the period referred to in the second indent of article 3.3.003.
- II. Any rider who has participated in any world championships, Olympic Games, continental championships or games, regional games, commonwealth games or world cup in the current year, except for the races that are open to masters only.
- III. Any rider who has participated in any other race on the UCI international calendar of the current year / season, except the races entered on the masters calendar.

(text modified on 19.09.06; 30.01.09).

Licenses

3.9.002 All applicants for the world masters championships must present a valid license to the event's race headquarters in order to be given a race number and be permitted to participate. The license must have been issued by the rider's UCI-affiliated national federation and must be valid for an entire calendar year.

3.9.003 In races other than the world masters championships, riders may participate with a temporary or daily license, issued by their national federation.

The license must clearly state the starting and finishing dates of its period of validity. The national federation shall make sure that the holder of a temporary license will, for the duration of his license, benefit from the same insurance cover and other benefits as those attached to an annual license.

World Masters Championships

3.9.004 Riders entered to compete in the world masters championships represent their country but are permitted to wear the clothing of their own choice.

3.9.005 All the details applying specifically to each world masters championship in each of the categories must be obtained from the organiser or on the UCI internet site.

3.9.006 Championships are normally organized in age groups of five years: 35-39, 40-44, 45-49 etc. Depending on the number of participants in each age group, the latter may be divided in age groups of less than five years or regrouped with an adjoining age group, in which case one single classification shall be drawn up.

There shall be no separate race for an age group if there are less than six participants in individual events or less than 12 participants in mass start events (i.e. points race).

(text modified on 25.01.08; 30.01.09).

Best Performances

3.9.007 The UCI track commission shall draw up a list of the best performances for masters set in time trial, 200 metres, individual pursuit and the hour for all men's and women's age groups.

(text modified on 25.01.08).

3.9.008 The UCI track commission must be informed of the best performances recorded in the World Masters Championships, using a confirmation request form for masters. The request must be accompanied by the following documents: proof of electronic or manual time-keeping; the place; the date and the nature of the competition; the result of the race in which the performance was recorded. The form must be countersigned by a UCI commissaire appointed for the event in question.

(article introduced on 13.06.08).

3.9.009 The UCI track commission must be informed of the best performances recorded in masters events, using a confirmation request form for masters. The request must be accompanied by the following documents: doping control form, proof of electronic or manual time-keeping; the place; the date and the nature of the competition; the result of the race in which the performance was recorded. The form must be countersigned by a UCI commissaire appointed for the event in question.

(text modified on 19.09.06).

3.9.010 The UCI track commission must also be informed of best performances recorded out of competition (ex.: best hour performance) using a confirmation request form. The following documents must accompany the request: doping control form, proof of electronic or manual time-keeping; the place; the date and nature of the performance. The form must be countersigned by a UCI commissaire who attended the performance.

3.9.011 The best performances shall be confirmed by the UCI track commission.

3.9.012 For anti-doping matters, see Part 14, and in all other respects, the rules for world records apply (chapter V).

(text modified on 13.06.08).

UCI CYCLING REGULATIONS

(Appendix 1)

UCI REQUEST FOR WORLD RECORD / BEST PERFORMANCE HOMOLOGATION

Date of the performance:
 Date of the request sent to UCI:
 (The request SHALL REACH the UCI no later than 1 month after the performance - Immediate notification by fax to UCI)
 Secretary General of National Federation:

VELODROME

Location of Track (City and Country):
 Track Measurement metres Material (wood etc.)
 Covered or Open:
 UCI Homologation Date:

INFORMATION FOR PROCESSING

Request for World Record / Best Performance Homologation for:
 (Men – Women – Junior Men – Junior Women – Masters Men – Masters Women)

Distance:

Start (standing or flying):

Date of attempt or event: Result:

Complete name of the rider: Nationality:

(Family)

(Given)

UCI Code: Licence number:

Laboratory in charge of Doping Control analysis:

Time of the attempt or event:

During an event / Special Attempt:

Resume of record:

Attestation of the result by Officials

We, the undersigned officials confirm that the record information as set out within this document was achieved according to the UCI Regulation.

Position	Name (family)	Given Name	Signature
UCI Technical Delegate			
UCI International Commissaires			
Official Timekeepers			
(manual)			
(electronic)			
UCI Doping Control Agent			

To be enclosed – Print out electronic timing slips
 – Doping control formular

Place and date

UCI International Commissaire Signature:

NB: This document is established in accordance with the World Records / Best Performances Regulations.